

Using Overland Storage® Snap Server® Storage Systems with MOBOTIX IP Network Cameras

A complete video surveillance solution using MOBOTIX high resolution megapixel cameras, MOBOTIX MxControlCenter software and Overland Storage Snap Servers

05 March, 2008

*Steve Rogers
Neil Cameron*

Table of Contents

Abstract	3
Overview	4
The Cameras	4
What is an IP Network Camera?	4
How are the Cameras Connected to an IP Network?	4
The Camera Monitoring Software	4
The Snap Server as the Network Video Archive	5
Snap Server Selection Guide	6
Overall Solution Configuration Steps	6
Best Practices	8
Calculating Your Storage Requirements	9
Optimal Performance Considerations	10
Network Bandwidth and Number of Cameras Supported	10
Replicating your Image Files to Another Site	11
How to Configure - the Specifics	12
Basic Snap Server Setup as the Camera Network Archive	12
Managing the Snap Server	12
To Connect Using the Server Name	12
Connecting to the Snap Server Using the Snap Server Manager Client Application	13
Accessing the Snap Server's Management Browser	14
Configuring the Snap Server to Accept Video Files from a MOBOTIX Camera	14
Configuring the Snap Server to Sync its Time with an NTP Server	16
Configuring the Disk Drives on the Snap Server	18
Creating Your Volume	20
Creating a File Share and Setting Security Access for the Cameras	21
Creating a Separate Camera User and Access to the Network Share	23
Mounting the Video Archive Network File Share on the PC Running MxControlCenter	26
Basic Camera Setup	28
Configuring External Recording and Viewing the Video Archive with MxControlCenter	29
How to Search Through the Network Video Archive Stored on the Snap Server	31
Configuring External Recording Using the Camera's Built-in Browser Administration	32
Configuring External Recording Using MxControlCenter	35

Abstract

The need for IP network video surveillance solutions continues to grow, with strong growth in such locations as retail shops, service locations, hotels, petrol stations, parking structures, apartment buildings, and homes. However most of the cameras used in surveillance are still based on a 60 year old analogue TV standard producing video that creates low quality images (0.4 megapixels) or lacks detail in the objects of interest. Additionally, most cameras are still tethered to coaxial cables, using midspan devices that concentrate a number of local cameras and long-haul the video over a single line to be recorded on a server, making installation more difficult and costly.

The evolution of cameras has introduced two new technologies to the surveillance market – high-resolution (megapixel) cameras and IP cameras (transmitting camera video over Ethernet networks). Camera manufacturers are introducing cost-effective high resolution digital cameras for surveillance solutions because of the growing importance of the quality of the images at both close range and at a distance. These new high resolution cameras deliver much better image resolution and quality, in most instances require fewer cameras (as a result of super wide angle optics which can cover an entire room), and with digital zoom capability, there is no need for a mechanical pan/tilt zoom implementation. For instance, if the goal of the surveillance project was to be able to read details like license plates or to distinguish objects at distances, high resolution cameras are the best choice.

The introduction of IP cameras that can connect to existing Ethernet networks has provided additional flexibility and scalability, and has reduced the cost of deployment. MOBOTIX has produced a versatile line of high resolution cameras that bring video surveillance to higher level, providing megapixel resolution (1024 x 768, 1280 x 960, and 2048 x 1536) video streams with audio and scalable frame rates. MOBOTIX cameras store these high resolution images more efficiently than other high resolution cameras, therefore requiring fewer network resources.

High resolution images can place a heavy demand on the network storage device required to process multiple camera streams and deliver the storage capacity and protection required for these images. When sizing any video surveillance application, there is always a tradeoff between the quality of the video, how long to store it, and the amount of storage required. With IP cameras, handling multiple camera streams over the network requires a recording server that can support multiple camera streams, since dropped frames would produce unacceptable results.

Recent testing of Overland Storage® Snap Server® storage systems in the MOBOTIX Camera Lab has shown Snap Servers to be an ideal storage solution for handling the demands from up to 80 simultaneous high resolution camera streams.

Snap Servers have a long history of being easy to manage, providing rock-solid reliability and offering a variety of integrated redundancy features. Snap Servers require fewer IT skills to manage, are more reliable, have a lower acquisition cost, and have a lower long-term cost of ownership than comparable general purpose PCs.

This paper will discuss key considerations and set up points for configuring a Snap Server as the IP video storage archive on the network; configuring MOBOTIX Cameras to record to the Snap Server; and how to configure the MOBOTIX MxControlCenter software to access and search the video archives stored on the Snap Server.

This paper will also discuss how to replicate files using Snap Enterprise Data Replicator (Snap EDR). Snap EDR is a secure WAN-tolerant network replication suite that can transmit video files to one or more Snap Servers, providing tiered archiving and added backup redundancy.

Overview

The Cameras

MOBOTIX Security Vision Systems, <http://www.mobotix.com>, offers a wide range of high quality network cameras for a variety of applications. Refer to their website for specifics and selection guides.

What Is an IP Network Camera?

A MOBOTIX IP network camera is a camera and computer combined into one intelligent unit. It captures and sends live high quality video directly over an IP network such as a LAN, intranet or the Internet. Users can view and manage the camera from any local or remote computer on the network, using a standard Web browser or video management software. Authorized viewers from different locations can simultaneously access images from the same network camera. The cameras create images in either MxPEG (a MOBOTIX proprietary format with a low network load) or JPEG (an industry standard format) file formats, with or without audio, which the cameras send over the Ethernet via TCP/IP to either the recording workstation or to a network storage device such as an Overland Storage Snap Server. Refer to the MOBOTIX website for more information on these formats and their benefits.

How are the Cameras Connected to an IP Network?

The cameras are powered either by a normal AC adaptor, then plugging the camera into a standard Ethernet Switch port using standard Ethernet Cat5/6 cables, or by an Ethernet switch designed to provide power over its Ethernet ports – referred to as Power over Ethernet (POE). Using a POE switch is beneficial, because it only requires a single Ethernet CAT-5/6 cable from a switch port to each camera to provide both signal and power to the camera. The camera runs on 3 watts, is weatherproof, and does not require any heating or cooling.

If switches already exist in the environment, a midspan can be added between the POE camera and the switch to power the camera, or an active splitter can be purchased to allow a non-POE camera to take advantage of a midspan or POE switch in an existing IP switched network.

Please refer to the MOBOTIX Web site for information on topics such as surveillance network design (bandwidth and storage), as well as camera types and sizing.

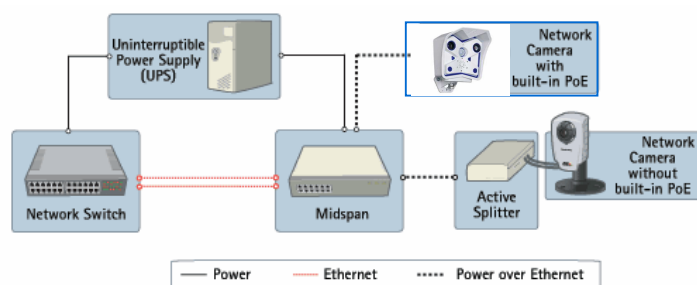

The Camera Monitoring Software

The MxControlCenter software is a comprehensive video management application specially designed to work with MOBOTIX cameras and local or remote video storage archives such as a Snap Server. It is easy to use and feature rich, providing camera setup, remote video monitoring and recording, and advanced camera event management capabilities. The software also provides a single interface for live and remote viewing of images from an unlimited number of cameras. The MxControlCenter also manages indexes for all video files it finds stored on the network archive, thereby enabling time searches and time synchronous playback of stored video.

The MxControlCenter software is downloadable from the MOBOTIX website free of charge to all MOBOTIX customers. The software can be run on any standard PC running Microsoft Windows XP or higher. Refer to the MOBOTIX website for system requirements and supported operating systems.

The Snap Server as the Network Video Archive

Snap Servers combine best-in-class network storage performance with a range of platform sizes, capacity points, RAID data protection schemes, and customer-centric ease of use – making them ideal for small offices, workgroups and larger distributed enterprises.

Built on the Linux-based GuardianOS™ Operating System, Snap Servers support network file sharing and easily integrate into existing networks and security infrastructures on a single device, providing a safe and secure video archiving solution.

Snap Servers are available in a variety of sizes, from 250GB desktop units to 19-inch rack mount systems that scale from 1TB to 88TB of raw storage capacity to fit a variety of video surveillance storage needs. Most Snap Servers also support multiple RAID data protection schemes, so critical video files remain safe and are available when they are needed.

Snap Servers provide cross-platform support, they can provide storage in several native formats. For the solution described in this paper there are two key protocols supported by the MOBOTIX Cameras. They are: CIFS (Microsoft) and NFS (UNIX/Linux). For this solution set, the focus will primarily be on CIFS. The Snap Server provides simultaneous support for both of these native protocols.

Microsoft Common Internet File System commonly known as CIFS – or an older version - Server Message Block (SMB) – is an application-level network protocol mainly applied to shared access to files. The network share created on the Snap Server provides the storage point on the network for archiving the video files.



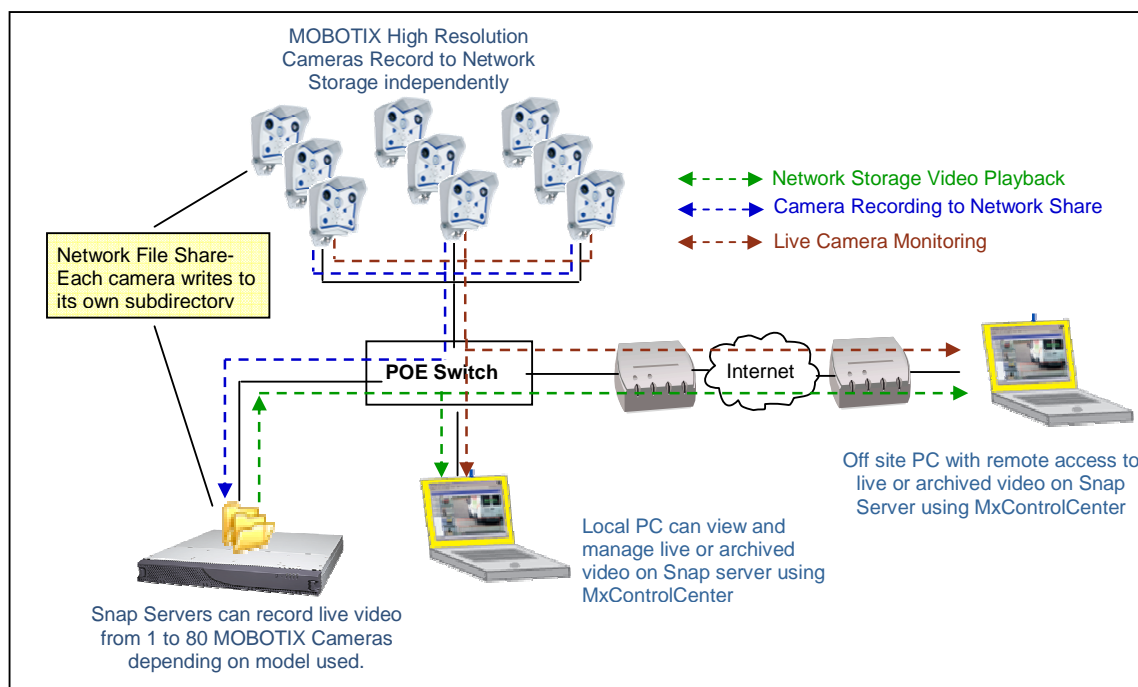

UNIX Network File System commonly known as NFS is a network file system protocol, originally jointly developed by Sun Microsystems and IBM in 1984. Similar to the purpose of CIFS, NFS allows a user on a UNIX/Linux computer to access files over a network. The network share created on the Snap Server provides the storage point on the network for archiving the video files.

The user configures one of these two protocols for the MOBOTIX cameras to write their video files over the Ethernet to the Snap Server's local storage. Each camera writes its images independently to a network share configured on the Snap Server.

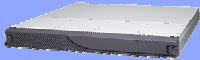

Snap Server Selection Guide

Snap Servers are available in a variety of sizes and configurations. Table 1 below will help you select the model and capacity to meet your surveillance needs. Snap Server 110 and 210 units ship with unconfigured hard drives, while Snap Server 410, 520, and 650 systems come preconfigured with a RAID 5 set. Snap Server 520 and 650 systems are expandable with Snap Expansion S50 2U 12-drive expansion arrays. Each Snap Server can support multiple cameras in either VGA or megapixel formats. VGA in Table 1 refers to 25fps.

Snap Server 110	Snap Server 210	Snap Server 410	Snap Server 520	Snap Server 650
				
GuardianOS	GuardianOS	GuardianOS	GuardianOS	GuardianOS
15 Cameras @ VGA 6 Cameras @ Megapixel	15 Cameras @ VGA 6 Cameras @ Megapixel	20 Cameras @ VGA 8 Cameras @ Megapixel	40 Cameras @ VGA 30 Cameras @ Megapixel	80 Cameras @ VGA 60 Cameras @ Megapixel
250/500/750GB (1 SATA II drive)	500GB/1TB/1.5TB (2 SATA II drives)	1/2/3/4TB (4 SATA II drives)	1/2/3/4TB (4 SATA II drives)	1.2 TB (4 SAS drives) High Performance
No Expansion	No Expansion	No Expansion	7, 2U x 12 Drive SANblocc 25.2 TB of SAS or 84 TB of SATA II	7, 2U x 12 drive SANblocc 25.2 TB of SAS or 84 TB of SATA II
1 GigE Port	1 GigE Port	2 GigE Ports	2 GigE Ports	2 GigE Ports
		Local Backup to Tape	Local Backup to Tape	Local Backup to Tape
Optional File Replication	Optional File Replication	Optional File Replication	Optional File Replication	Optional File Replication
Single Drive	Two-Drive RAID 0, 1	4 Drive RAID 0,1,5 Hot Spare	4 Drive RAID 0,1,5 Single/Dual Power Hot Spare	4 Drive RAID 0,1,5 Dual Power Hot Spare
Desktop Height 3.1" (78.74mm) Width 6.1"(154.9mm) Depth 10.1"(256.5 mm)	Desktop Height 4.3" (109.22mm) Width 6.1"(154.9mm) Depth 10.5" (266.7 mm)	1U Tabletop or Rack Height 1.75"(44.45mm) Width 16.7" (424.3mm) Depth 19.2" (487.7mm)	1U Rack mount Height 1.75"(44.5mm) Width 17.5"(444.5mm) Depth 29.25"(742mm)	1U Rack Mount Height 1.75"(44.5mm) Width 17.5"(444.5mm) Depth 29.25"(742mm)

The benefits of the MOBOTIX/Snap Server solution include:

- High resolution video and audio capture over IP networks
- Archive functions already integrated into the camera – each records their images to the Snap Server independently for ease of management, maximum flexibility and scalability
- Each high performance Snap Server storage system supports multiple cameras
- Choose the right-sized network storage system for each site – large or small
- Modularly expandable storage provides longer retention times of higher resolution images
- Easily manage one or many geographically dispersed Snap Servers
- Proven rock-solid reliability provided by Linux-based GuardianOS operating system
- The Snap Server supports a controlled power-down and a power-up after a voltage interruption

- Snap Servers all run the same operating system and use the same management interface, making setup and configuration consistent across all Snap Server models
- MOBOTIX cameras and Snap Servers both allow independent scalability in the project
- The Snap Server supports a fast MxCC-Playback over the GB port

Overall Solution Configuration Steps

This section provides an ordered summary of the steps necessary to configure the solution. The setup assumes you already have a PC running at least Microsoft Windows XP with access to the network on which you intend to configure your cameras, as well as a functional network browser (like Internet Explorer). A DHCP server could also be present on the network for automatic IP address assignment, or the IP addresses can be configured manually. Initially, both the PC and the Snap Server must be on the same network subnet.

1. Plan your environment: define IP addresses, usernames/passwords, and network share name(s) in advance
2. Configure the Snap Server
 - ✓ Connect at least one Ethernet port on the Snap Server to the network where the cameras are located, then power the unit on
 - ✓ Install Snap Server Manager (SSM) from the Snap Server CD on the management PC (most likely the same PC on which MxControlCenter is installed, though this is not a requirement). SSM is used to locate the Snap Server on the network and log onto the management user interface of the Snap Server
 - ✓ Set up the Server Name, System Date and Time
 - ✓ Set up NTP (if necessary) and email alerts
 - ✓ Register your Snap Server
 - ✓ For security purposes change the default administration password for the Snap Server
 - ✓ Configure appropriate Network Settings for the IP Subnet you intend to use for the cameras
 - ✓ Verify that the Disk Drives have been configured in the appropriate RAID Set.
 - ✓ Verify that the Data Volume has been created
 - ✓ Create File Share and set share access control for the camera (one user for all the cameras is usually sufficient for most applications)
 - ✓ Create another share access control for the MxCC-playback (set to “read only”)
3. Configure any other services you may need, such as Active Directory, for your environment. These items are not covered in this document – please refer to the Snap Server Administrator Guide for more information
 - ✓ Install, Connect, and Configure Cameras on the IP Network
 - ✓ Add MOBOTIX cameras to the network and connect to the network switch according to MOBOTIX instructions
 - ✓ Determine whether you want to configure the cameras manually or through the MxControlCenter
 - Refer to the MOBOTIX camera manual (section 5.3: *Quick Install*) if configuring the cameras individually
 - Set the event control (events, actions and messages). See chapter 7: *Events, Actions and Messages*, in the software manual
 - Set the external storage access to the network Share via either CIFS (recommended) or NFS

- Verify that the configuration in each camera is permanently stored (flash)
- If configuring the cameras using MxControlCenter, install the MxControlCenter. Refer to the MxControlCenter software manual, section 2.2, to automatically discover and configure the cameras
 - Follow the MxControlCenter manual section 1.3.7: *Configuration of the Recording and Storage Functions*, to set each camera to record to the established Snap Server Network Share
 - Set the external storage access to the network Share via either CIFS or NFS
 - Follow the MxControlCenter manual for your monitoring layout, setup, and configuration
- ✓ If desired, change the default administration password for each camera for added security

Best Practices

- 👍 Determine and plan the IP infrastructure for your cameras, Snap Server and monitoring PC before you begin configuration. Document the IP address ranges, usernames and passwords you want for the Surveillance environment.
- 👍 Consider whether you want all cameras to access a single Network Share set up on the Snap server using the same username and password. Alternatively, you may want each camera to have a unique username and password.
- 👍 Gigabit Ethernet is preferred for maximum bandwidth. All Snap Server systems use 10/100/1000 auto sensing Gigabit Ethernet ports.
- 👍 Separate your Video Camera network from your standard Client Network traffic. A standard IP switch with VLAN capability will provide the proper dedicated bandwidth and isolation.
- 👍 It is best to set a static IP address for the cameras, as well as the Snap Server. This way, they are guaranteed to never change.
- 👍 For security reasons, change the administration password of all cameras and Snap Servers. Retain these passwords in a safe place.
- 👍 When calculating the amount of network storage needed, be sure to add at least 15-20% for future growth.
- 👍 The Snap Server and all cameras should sync to a common time source on the network. It is recommended to use NTP for time synchronization.
- 👍 Neither Network Share names, nor user names should contain spaces.
- 👍 Only a single Network Share is required for the cameras to write to the Snap Server.
- 👍 Be sure to configure the Snap Server email alert mechanism so you will be notified of any issues with the Snap Server such as an out of storage space condition.
- 👍 Activate the Fileservercheck in the admin menu of the camera, to receive notifications (email, Voicemail...) of any issues with the connection to the Snap Server.
- 👍 Activate the Time Server settings in both Systems (Snap Server and MOBOTIX) to synchronize all video data to the same time.
- 👍 Snap servers should be on a UPS, to prevent data loss in case of unexpected power outages.

Calculating your Storage Requirements

There are many factors that affect the amount of storage required. MOBOTIX has considerable information already on their website and in their camera manuals regarding this subject. The key attributes to consider are:

- Image size – a factor of resolution and image quality
- Single or dual lens recording (example 1280x960 or 1560x960)
- Frames per second when recording
- Recording format – compression type
- Percent of compression – a factor in the quality of the image
- Number of hours of camera recording per day
- Days of video retention

MOBOTIX has a calculator tool that can assist you in calculating the amount of storage you will need. As of the writing of this paper it is not yet on their Web site. Check with your MOBOTIX representative to obtain this tool.

The table below is a quick reference to give you an idea of the maximum amount of total storage that would be needed in three image complexity scenarios for MxPEG recording format. All storage capacity below is in Gigabytes per camera, per day of retention.

	Quality = 60%, Recording Mode = Continuous, Resolution = VGA (640 x 480)								
Image complexity	Low	Med	High	Low	Med	High	Low	Med	High
Frame Rate (fps)	Max (quality)	Max (quality)	Max (quality)	12	12	12	4	4	4
Per day with audio (GB)	13.4	20.1	26.8	11.95	17.9	23.9	9.1	13.6	18.1
Per month with audio (GB)	405.9	604.4	805.8	358.4	537.6	716.8	271.9	407.8	543.8
Per day without audio (GB)	12.7	19.6	25.5	11.3	16.93	22.6	8.4	12.6	16.8
Per month without audio (GB)	383.1	574.7	766	338.6	507.9	677.3	252.1	378.2	504.2
Number of Cameras	15	15	15	15	15	15	15	15	15
Capacity per day (GB)	201	302	402	179	269	359	137	204	272
Capacity per month (GB)	6,089	9,066	12,087	5,376	8,064	10,752	4,079	6,117	8,157
number of Cameras	40	40	40	40	40	40	40	40	40
Capacity per day (GB)	508	784	1,020	452	677	904	336	504	672
Capacity per month(GB)	15,324	22,988	30,640	13,544	20,316	27,092	10,084	15,128	20,168

Frame Rate – Quality assumes 16,8fps, 60% compression
1000 Gigabytes = 1 Terabyte

	Quality = 60%, Recording Mode = Continuous, Resolution = Megapixel (1280 x 960)								
Image complexity	Low	Med	High	Low	Med	High	Low	Med	High
Frame Rate (fps)	Max (FastMode)	Max (FastMode)	Max (FastMode)	Max (quality)	Max (quality)	Max (quality)	4	4	4
Per day with audio (GB)	25.2	37.8	50.4	23.9	35.9	47.9	22.9	34.3	45.8
Per month with audio (GB)	756.4	1,110.0	1,480.0	719.3	1,005.0	1,400.0	687.2	1,001.0	1,340.0
Per day without audio (GB)	24.5	36.8	49.1	23.3	34.9	46.4	22.2	33.3	44.5
Per month without audio (GB)	736.6	1,008.0	1,440.0	699.5	1,002.0	1,370.0	667.4	980.0	1,300.0
Number of Cameras	6	6	6	6	6	6	6	6	6
Capacity per day (GB)	151	567	756	359	539	719	344	515	687
Capacity per month (GB)	4,538	16,650	22,200	10,790	15,075	21,000	10,308	15,015	20,100
Number of Cameras	30	30	30	30	30	30	30	30	30
Capacity per day (GB)	735	1,472	1,964	932	1,396	1,856	888	1,332	1,780
Capacity per month (GB)	22,098	40,320	57,600	27,980	40,080	54,800	26,696	39,200	52,000

Frame Rate - Quality assumes 16.8fps, Max (Fast Mode) assumes 30fps, 60% compression

Optimal Performance Considerations

Depending on the type and capacity of the Snap Server chosen, relatively large configurations of MOBOTIX cameras can be supported. The Snap Server 520 and 650 are scalable to 88TB, thereby enabling additional flexibility by allowing for longer surveillance image retention.

Network Bandwidth and Number of Cameras Supported

All Snap Servers use Gigabit Ethernet ports with auto sensing, so they will negotiate down to a transmission speed that the Gigabit Switch can support.

A good rule of thumb to use when determining the number of cameras the available network can support is that a single MOBOTIX camera can consume anywhere from about 2Mbps to 4Mbps of network bandwidth based on 25fps VGA quality with audio. However, a variety of factors such as frame rate, image quality and motion type may significantly decrease the bandwidth consumed.

For larger camera installations, a Gigabit Switch is recommended (e.g.: 48 Ports 100Mbit/2 Ports Gigabit). You should take care to ensure that:

- the internal Switch backbone has enough internal bandwidth to support 50 cameras, in addition to the File Server traffic
- the Switch supports Gigabit uplink to connect the Snap Server and the PC with MxCC

The advantage of the Gigabit Ethernet connection(s) on the Snap Server:

- Supports fast MxCC Playback (the direct connection between the PC and the Snap Server over a Switch with Gigabit uplinks)
- Provides the additional bandwidth and second Gigabit port to allow fast Video File Transfer for Backup or Replication with Snap EDR

Replicate Your Image Files to Another Site

Snap Servers are designed to run a select set of 3rd party applications that provide additional value to your surveillance project. One optional application, Snap EDR, is a robust WAN tolerant, asynchronous file replication suite.

Snap EDR has the following key features:

- Replicates one-to-one or one-to-many locations
- Replication jobs can be scheduled up to the minute, or by date and time for unattended operation
- WAN tolerant, secure, and network bandwidth aware
- File compression and encryption for safe and efficient data transfer over the network

Key values Snap EDR brings to the surveillance project:

- Centralized management of replication jobs
- Bandwidth throttling to minimize the impact to the network
- Scheduling of replication jobs for unattended operations
- Individual image files or entire camera directories can be replicated to another location or to multiple locations for second site analysis, backup, or disaster recovery operations

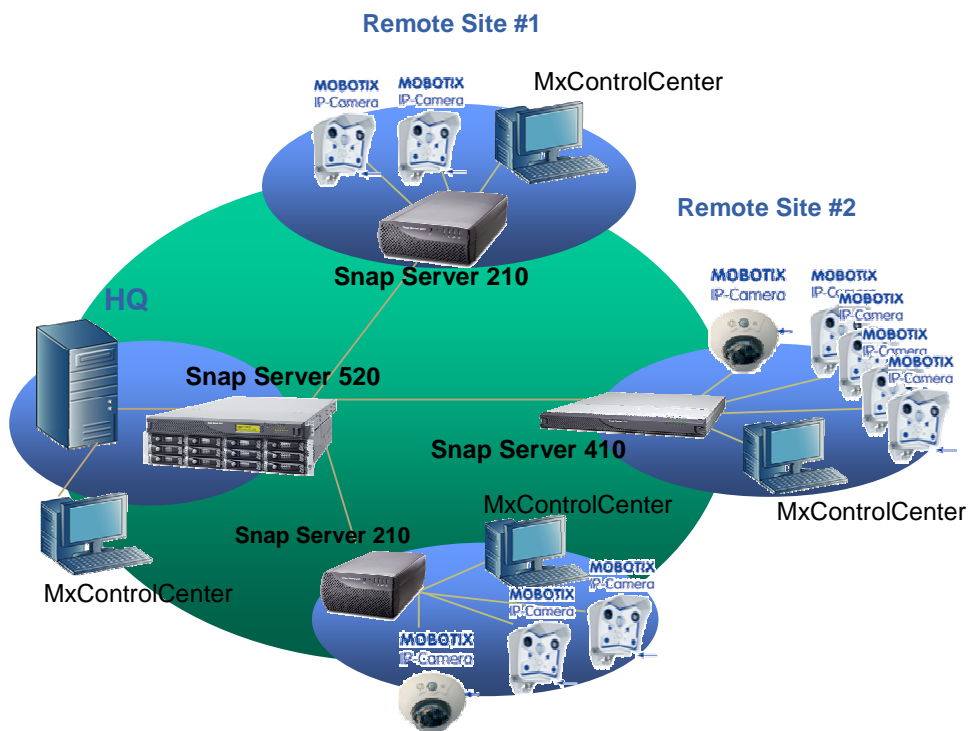

How to Configure - the Specifics

Basic Snap Server Setup as the Camera Network Archive

Since Snap Servers come in various capacities, there are a few natural variations in the configuration steps. Each Snap Server system comes with an initial configuration wizard that walks you through the basic steps required to configure it for your network. If you follow the setup wizard you will end with a configured drive (or RAID set), a volume, and a Network Share named "share1". The Network Share can then be accessed on the network by a standard network mount, for instance as a Microsoft Windows share mount: \\[IP Address]\share1.

Since no security controls will be present on this Share, it can be accessed by anyone with the IP address and Share name. Therefore locking down security on the box is recommended, once you have set up the snap. This method is similar to the MOBOTIX camera in its default configuration.

Managing The Snap Server

Snap Servers are managed through a Web Browser. Unlike a generic PC, Snap Servers do not require any directly connected keyboard, mouse or monitor. You simply open a network browser (like Internet Explorer) on a PC which is on the same network as the Snap Server. If the network includes a DHCP server, the Snap Server will be assigned an IP address by default.

An LCD panel is located on the front bezel of Snap Server 520 and 650 systems. Once a cable is plugged into Ethernet port 0 on the back of the unit, this LCD panel will display the IP address that has been assigned by the DHCP server. If this LCD panel shows IP address 10.10.10.10, either there was not a DHCP Server present on the network, or the cable was inadvertently plugged into Ethernet port 1. Note that port 0 is the left-hand port when viewed from the back of the Snap Server.

If no DHCP server is present, the Snap Server will require a static IP address. You can momentarily change the PC to IP address 10.10.10.11 then, through your network browser, access the Snap Server by entering the URL address: <http://10.10.10.10> . Now you can proceed to **Accessing the Snap Server's Management Browser** to configure the Snap Server. Once you have set the Snap Server to the correct IP address you can reset your PC back to its original configuration.

No LCD panels are present on Snap Server 110, 210, or 410 units. Therefore, accessing the Snap Server will require one of the following methods:

1. Use the Server Name

This procedure requires that name resolution services (via Windows Internet Naming Service [WINS] or Domain Name System [DNS]) are operational in your network environment.

- Find the server name

For Snap Server 110, 210 and 410 units, use the default server name of *SNAPnnnnnn*, where nnnnnn is the server number. For example, the name of a Snap Server with a server number of 610019 is *SNAP610019*. The server number is a unique, numeric-only string that appears on a label affixed to the underside of the chassis of your Snap Server 110 or 210. To obtain the server number for a Snap Server 410, remove the front bezel to read the label.

- Connect to the server

In a Web browser, enter the following URL:

<http://SNAPnnnnnn> (where nnnnnn is the server number)

Press Enter. The Web View screen will open. Proceed to *Accessing the Snap Server's Management Browser*

2. Use the Snap Server Manager Client Application

Included on a User CD, which ships with every Snap Server, is an application called Snap Server Manager (SSM). It is a Java-based, platform-independent, multiserver administrative application from which administrators can discover, configure, and monitor all Snap Servers on their network. With SSM, administrators can compare, copy, and configure settings for groups of GuardianOS Snap Servers in a single operation.

SSM can be installed to all client platforms, including Windows, Macintosh OS X, Linux, and UNIX. It is a convenient practice to install SSM on the same PC where you intend to run MxControlCenter, since it enables the administration of the cameras and the Snap Servers from the same PC. SSM can be run from any PC that is routable to the network where the Snap Server is located. Once SSM is installed and the application has started, you will see the application image similar to the image below:

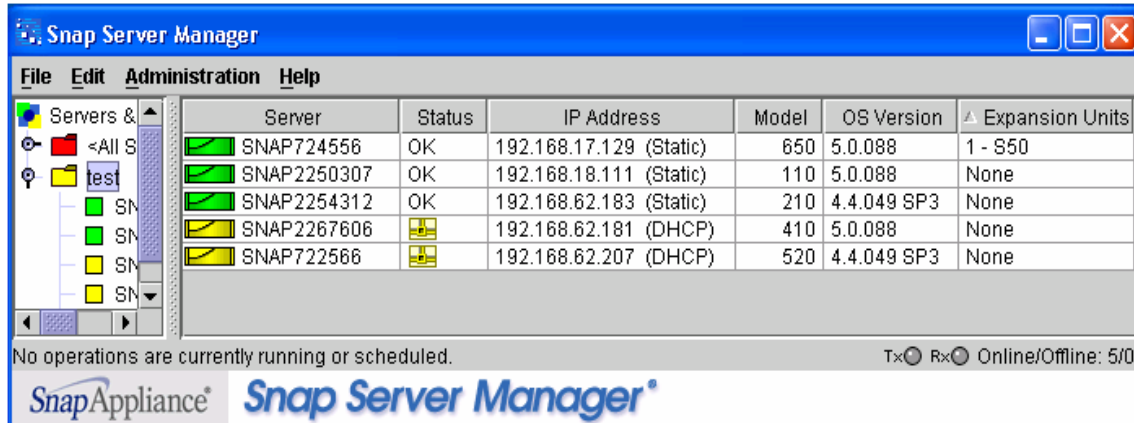

Note the Server name, IP address (static or DHCP) and model are clearly displayed. Once you have identified the Snap Server you wish to configure, place the mouse over its row to access its administration browser. Right-click, move the mouse to **Launch Web Administration** on the pull down menu, then left-click to select.

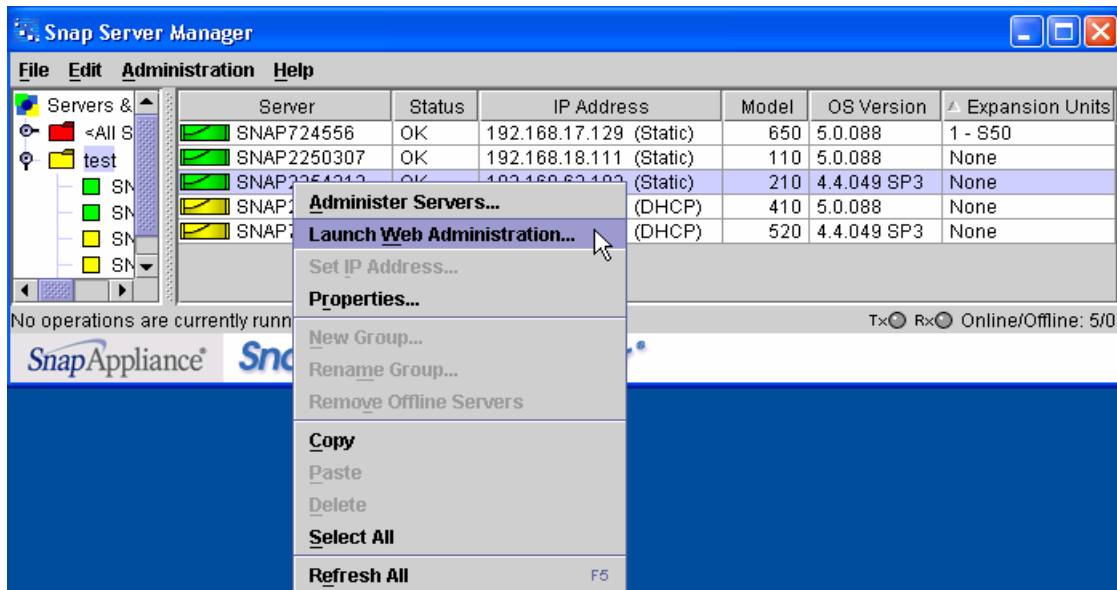

Note the grayed-out **Set IP Address** in the pull down menu. This can be used to set the initial IP address if no DHCP server is present and the Snap Server has defaulted to 10.10.10.10.

Accessing the Snap Server's Management Browser

Your default browser window will open and you will get a dialogue box to enter the Snap Server's Username and Password. The defaults are: admin/admin. This should be changed later under the security section.

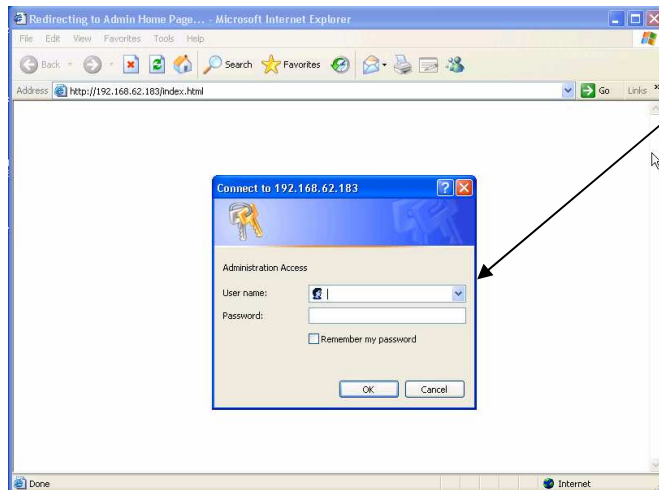

Enter
Username: admin
Password: admin

In this example, we are using a Snap Server 210 for our configuration. It is a 2 drive desktop model with non-configured drives.

This section describes setting up the Snap Server using the fewest number of steps for a *Basic setup*. The Snap Server has many additional features and security attributes that may prove useful, like Microsoft ADS integration, Alerts, and other file sharing capabilities.

Configure the Snap Server to Accept Video Files from a MOBOTIX Camera

1. Power up the Snap Server and connect it to the network. The Snap Server provides a 10/100/1000 auto sensing NIC port so it can handle plenty of bandwidth if you have a Gigabit network. The unit will take several minutes to boot up and you will hear the internal fan until the operating system takes control of the environmentals, then it will quiet down significantly. All Snap Servers have a "heart beat" LED on the front of the bezel. When it is blinking at the rate of one blink per second the unit is up and ready to be accessed from a network browser.
2. The first assumption we will make is that the Snap Server is being connected to a network that has a DHCP Server present, enabling the Snap Server to get its IP address assigned automatically and register itself with your local DNS server. If you do not have a DHCP Server or want to manually set up the IP address, refer to the online help or manual on the CD provided with the unit. Follow Step 4 to set the IP address manually if you are familiar with setting up IP addresses.
3. When you log in for the first time you will see the following web page titled Initial setup: General Information:

Initial Setup: General Information

Enter basic information for the server.

Server Name: SNAP2250307

Date: 04 / 06 / 2007 (MM/DD/YYYY)

Time: 22 : 58 : 59 24 Hour

Time Zone: (UTC) Coordinated Universal Time

Admin Password: (Leave blank to keep existing password)

Password Confirm:

Warning: You should assign an administrator password if you want to protect your server from unauthorized changes.

Next Cancel

4. Set the date, time, time zone, and administrative password, then click **Next**. If an NTP time server is present, it will be configured later. All cameras and Snap Servers should be synchronized to the same time.
5. This next page will allow you to configure the Snap Server's IP address. You can manually set the address or set it obtain an IP address automatically if you have a DHCP server present. Note the IP address and other information in the white boxes in the static area – these are the settings that are currently assigned from either your DHCP server or from your previous static settings.

Initial Setup: Configure TCP/IP Address for Ethernet 1

Accept the default DHCP-assigned address or enter a static address.

Obtain TCP/IP settings automatically using DHCP

Set IP address as static using the settings below:

IP Address: 10.10.10.10

Subnet Mask: 255.255.255.0

WINS Servers: 10.10.10.10 (optional)

10.10.10.10 (optional)

(optional)

(optional)

Default Gateway: 10.10.10.10 (optional)

DNS Domain Name: yourdomain.com (optional)

Domain Name Servers: 10.10.10.10 (optional)

10.10.10.10 (optional)

(optional)

Next Cancel

6. After making your selection and inputs click **Next**
7. Basic setup is now complete. Select **OK** to continue setting up your storage, network share (the network location where the video files will be stored), and setting security access to that share.

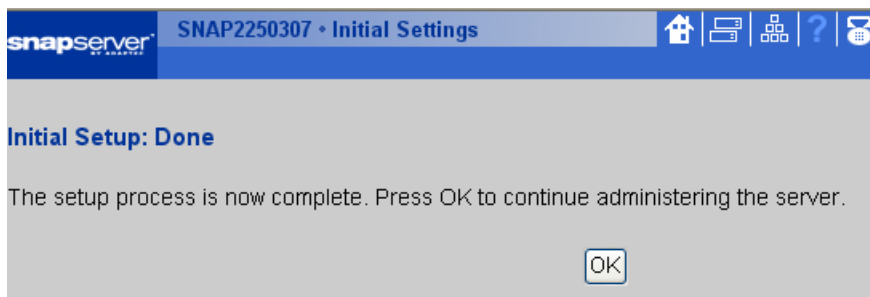

- At this time, you should configure email alerts, so any Snap Server errors can be reported to the administrator. Note: an SMTP Server must be present and routable to the Snap Server for reporting via email to work. Up to 4 addresses can be entered for notification.

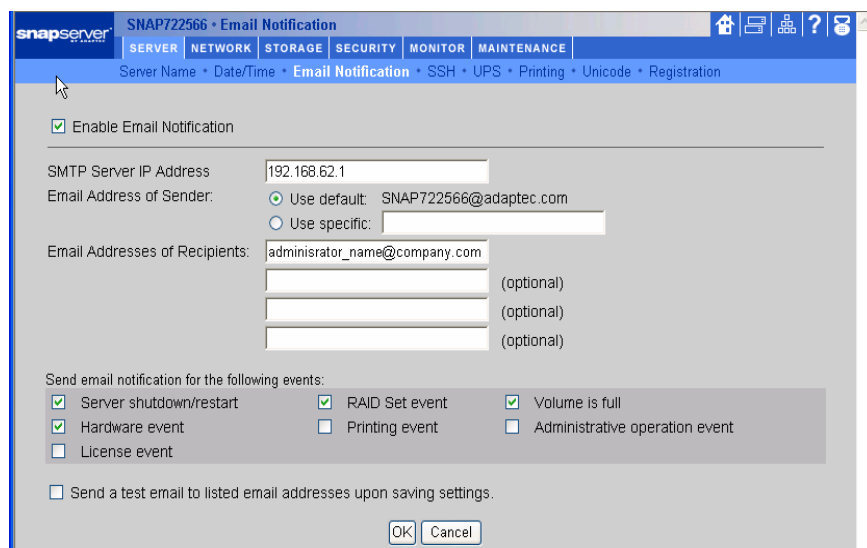

Configuring the Snap Server to Sync its Time with an NTP Server

One other important step to be completed is configuring the Snap Server to synchronize itself to an NTP Time Server. This setting can be the same NTP server utilized by the cameras for synchronization.

To configure NTP, go to the Server, Date/Time Page and click on the **Advanced** Button at the bottom of the page.

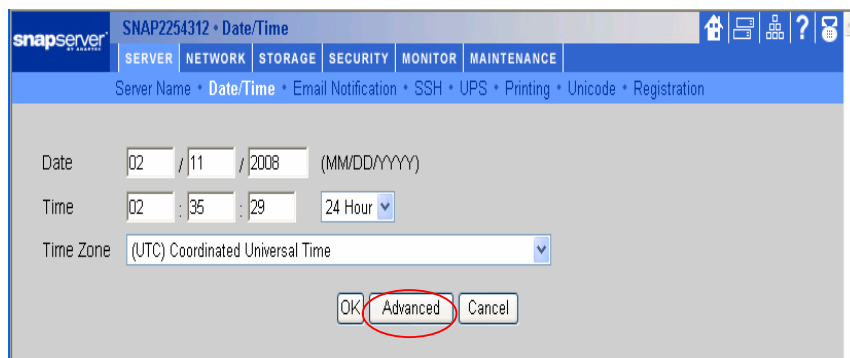

The screen shown below will appear. Select “Automatically synchronize this server’s date & time to the following NTP server(s)” and enter the appropriate NTP server name(s). You can find a list of public NTP servers at <http://www.ntp.org>. Due to security restrictions, NTP cannot be used when the Snap Server is joined to an Active Directory domain. The AD domain server will keep the time synchronized between the Snap Server and the AD server.

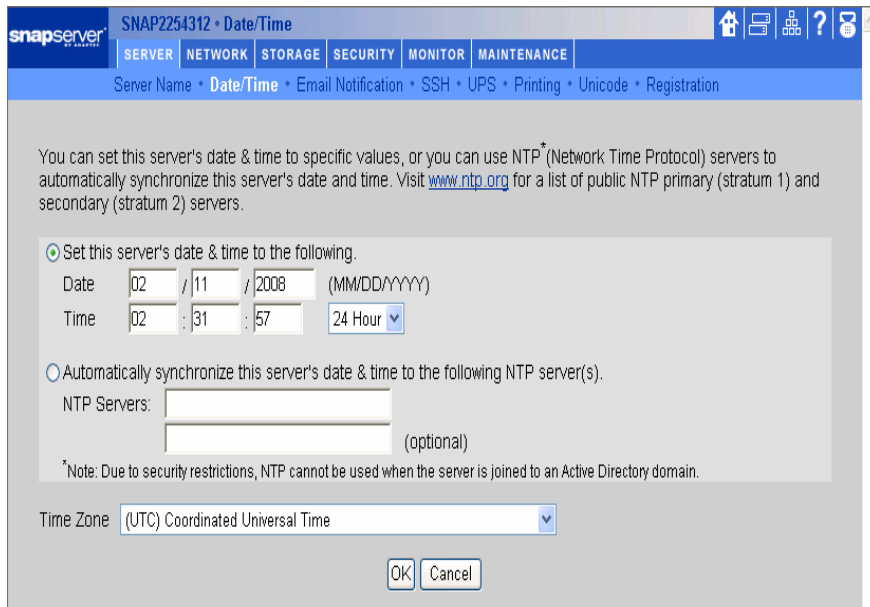

One other important step is to register your Snap Server, so Overland Storage can inform you of OS updates and important technical announcements.

Overland Storage has a strict privacy policy and does not share information with other third parties.

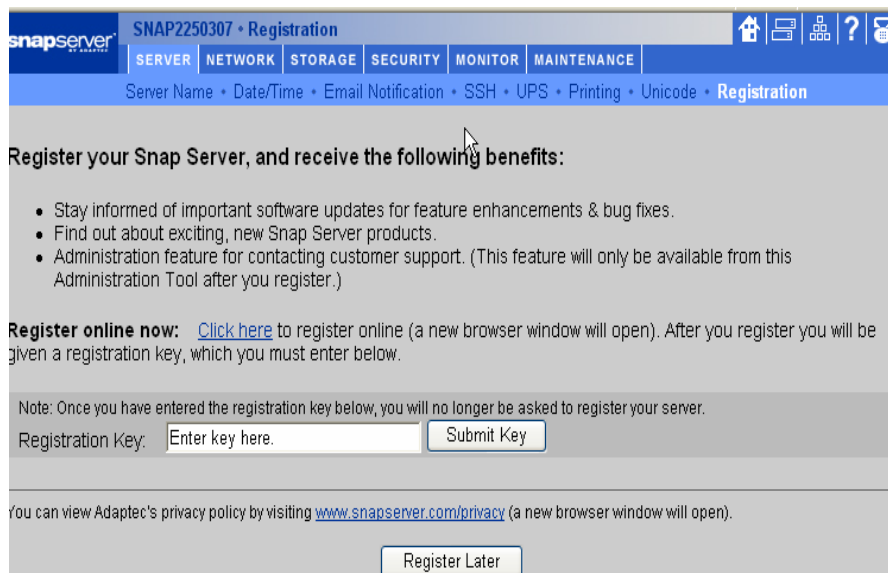

The registration key will prevent this screen from appearing every time you login to the server.

Configuring the Disk Drives on the Snap Server

You have now entered the main administration page for the Snap Server. From here, you can navigate to any function you want to set up. First we will navigate to the **RAID Sets** page to configure the two disk drives in the unit.

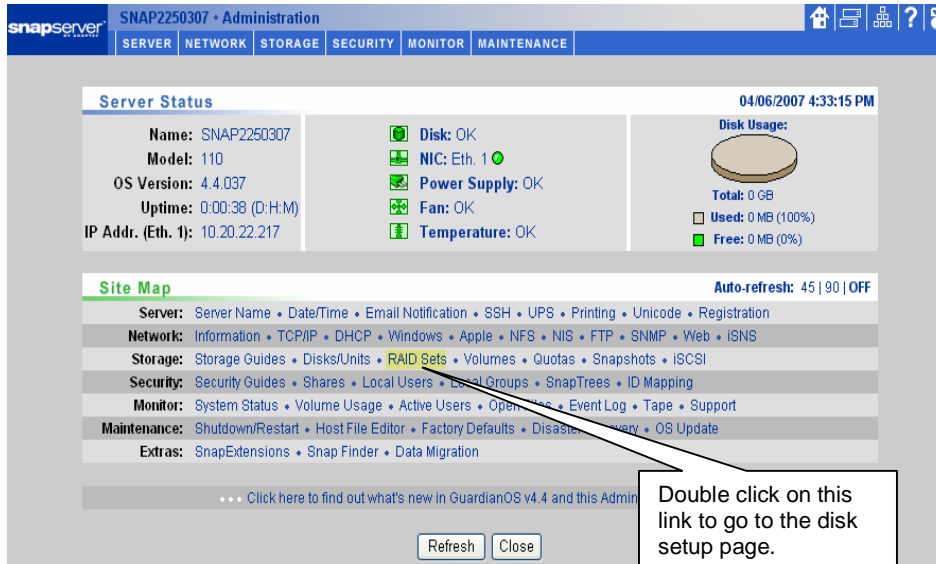

At this stage, there are no drives configured. Click on the **Create RAID** button to create your RAID set.

In this example, using the two-drive Snap Server 210, the user has the choice of selecting RAID 0, which uses the available capacity of both disk drives or RAID 1 to utilize the available capacity of a single disk drive, while maintaining an exact copy of the first on the second drive. This is referred to as mirroring. For the best data protection, a RAID 1 mirrored configuration is recommended. In the event a drive fails, you will still have a valid, accessible copy of your data on the second drive.

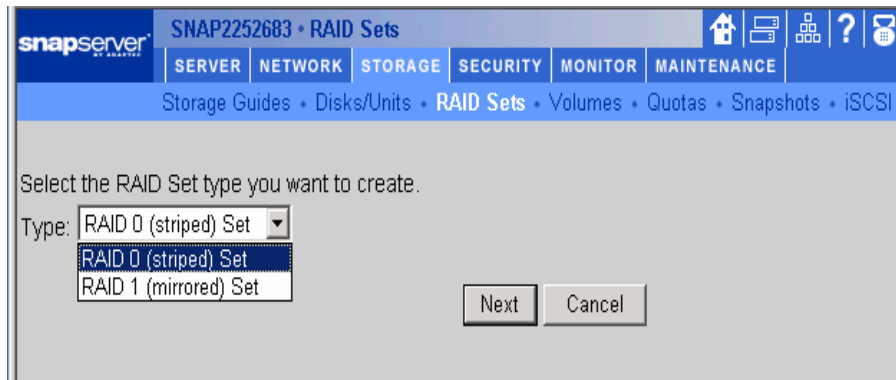

Using the pull-down list, select the RAID type desired, then click Next to proceed.

If using the recommended RAID 1 configuration, check both boxes on the left, then click the Next button at the bottom of the page.

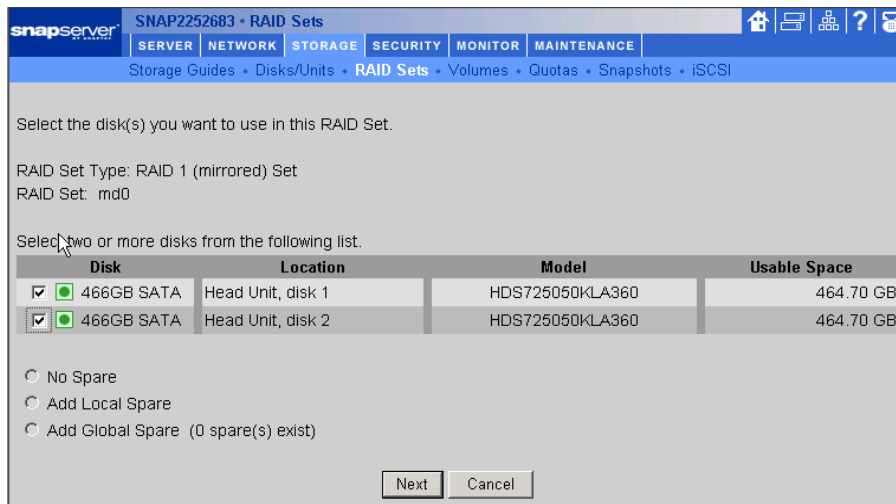

One last confirmation page, before execution of the RAID build task begins. Click Next to proceed with building the RAID.

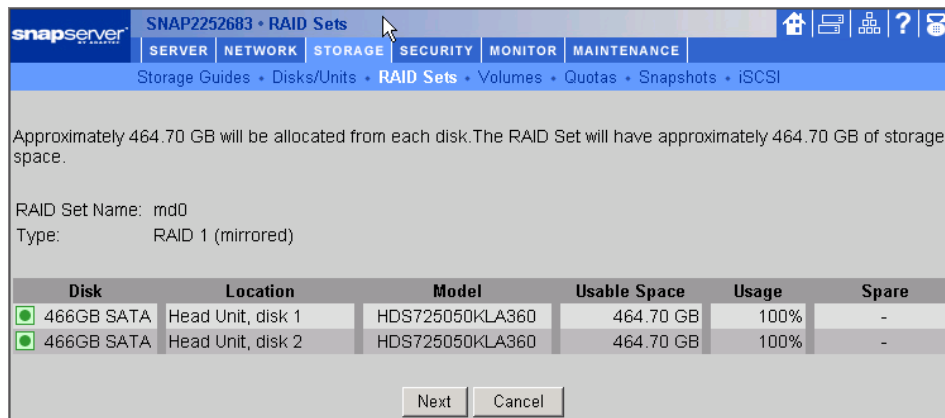

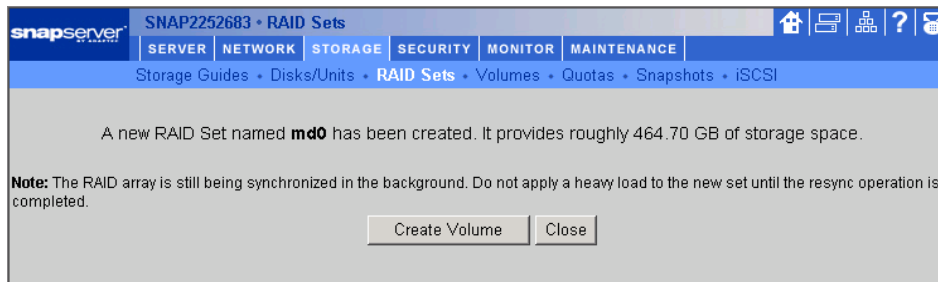

The RAID set will be created in the background. Depending on the size of the drives, it could take upwards of a few hours to complete the RAID resynchronization. The rest of the setup can continue while the resynchronization occurs in the background. Proceed to the Volumes page.

Creating your Volume

Now we will create a single Volume using all the available space on the RAID set for File Sharing.

Click on the **Storage** link in the top menu and then the **Volumes** link in the lower menu to get to the Volumes page. Click on **Create Volume**



A page will appear that will allow you to choose the Volume Name and the size of the volume. Since all drives were consumed when building the RAID set, you will only have one RAID set to choose from. The default Volume name is **VOLO**.

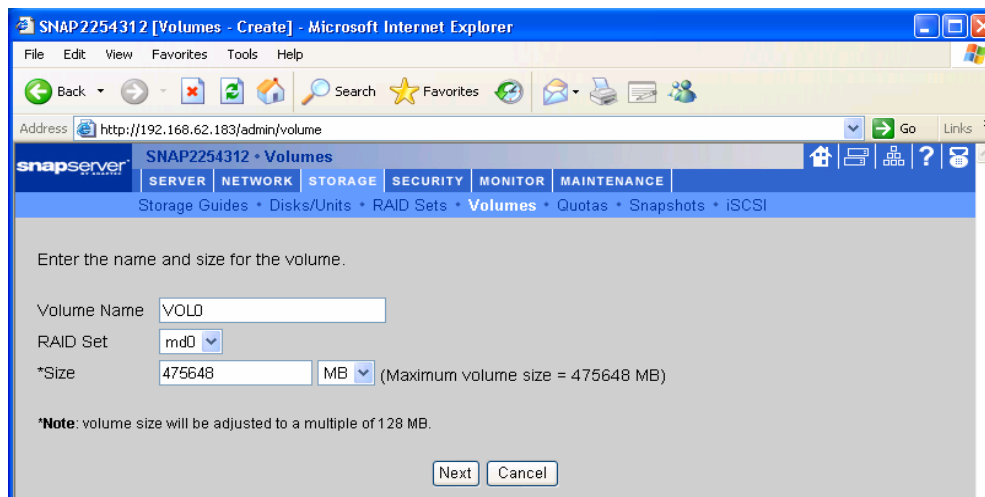

You will then see a summary screen based on what you entered. If you made a mistake click the browser back button. If all is correct, select **Next**

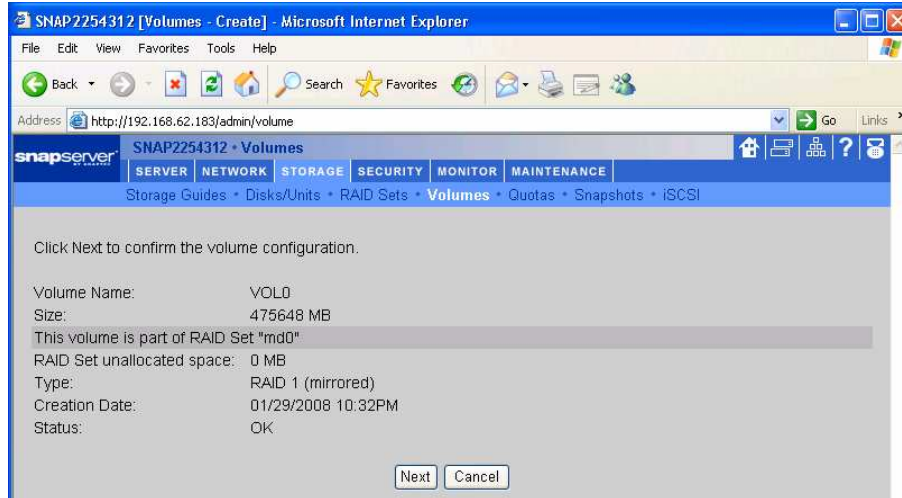

You should soon see the Volume confirmation screen. The Volume is now created.

You can now proceed to set up the Network Share and set security access

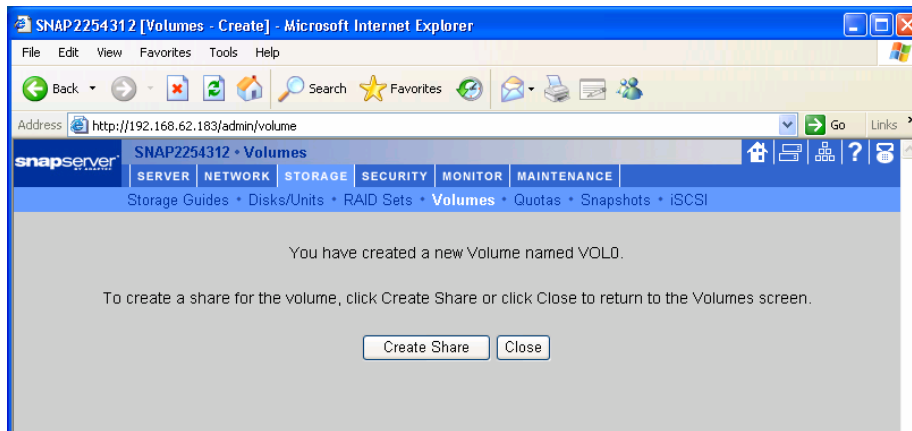

Creating a File Share and Setting Security Access for the Cameras

You should consider whether you want all cameras accessing a single Network Share set up on the Snap server using the same username/password. Alternatively, you may want each camera to have a unique username and password. For large installations, this could become a tedious task to set up, in addition to maintaining the list of usernames and passwords associated with each piece of equipment.

Setting up a unique username and password for each camera can frustrate a potential hacker and severely limit the potential for damage, in the event he successfully gains access to the camera network. Conversely, if only a single username and password system had been employed, a successful breach would give the hacker access to all the cameras, as well as to the Snap Server archive.

Setting up the Share is the most important step in the process, because it will be seen by the MxControlCenter and all cameras and on the network, and sets up security access to determine which cameras can access the Network Share. MOBOTIX Cameras can all access the same Share, because each camera creates its own unique folder in the Share, then writes its video clips underneath that folder.

The unique camera folder name, created by the camera, will be the camera's IP address set at the factory, so make sure you are aware of this IP address.

Select **Security** from the top menu, then **Shares** to create a Share and apply security access. Select the **New** button to begin creating the Share.

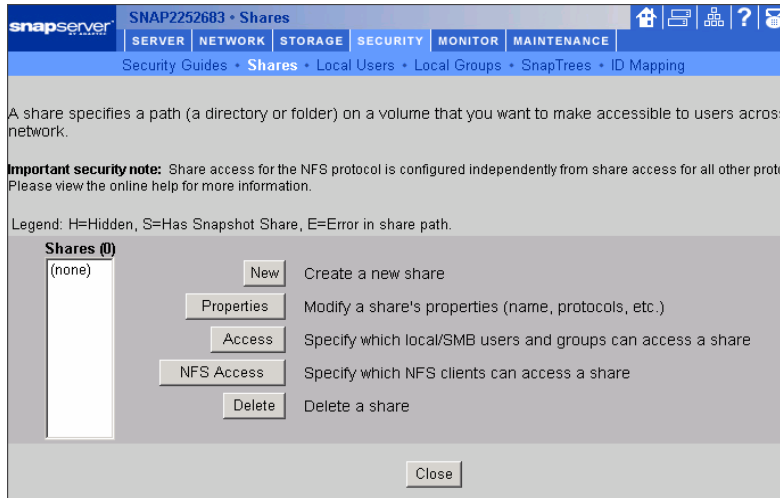

SHARE1 is the default name. We will change it to **VideoArchive**. This Share name is part of the path required by the cameras. Next we will control access to this Share.

The Share name, which is case sensitive, cannot contain any spaces or special characters.

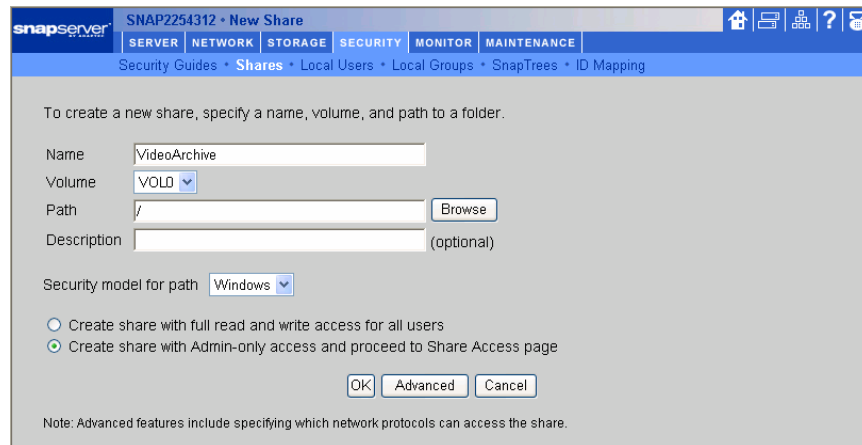

By clicking on the **Advanced** button, you can further tighten access to this Share by selecting the boxes below to only allow Microsoft access to this Share. You can also hide this share from network browsing by other clients, so users must know the Share name to successfully access it. This feature is recommended to have a higher security level to thwart unauthorized intrusion.

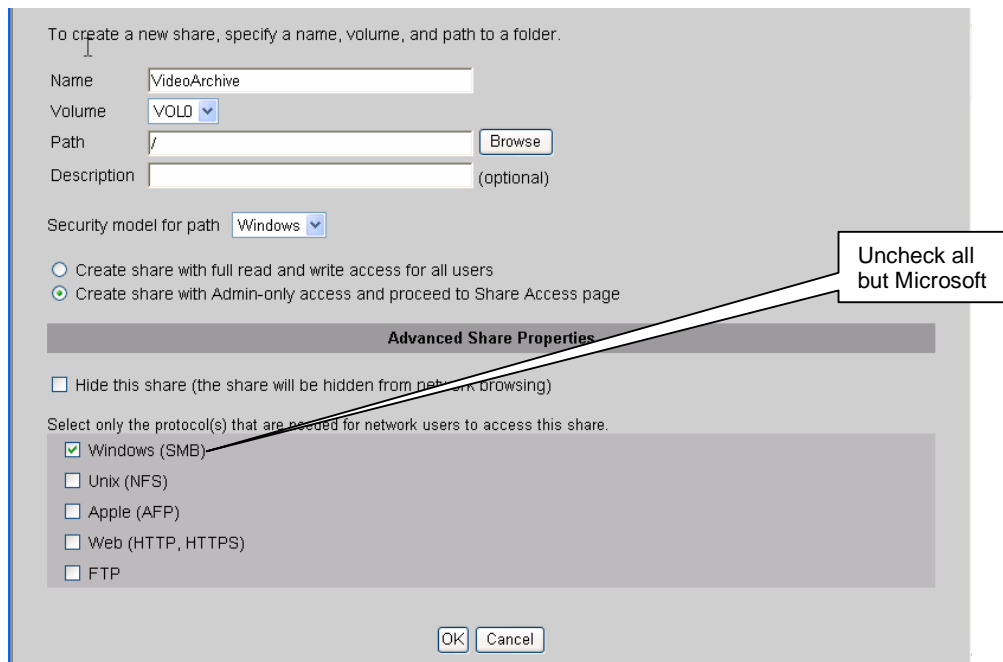

Click **OK** to complete setting up the **VideoArchive Share**. In this configuration, the **VideoArchive Share** will only be accessible by a CIFS client and only after entering the previously assigned Snap Server Administration username and password.

As outlined in the best practices section, you must determine if you want all cameras accessing the **VideoArchive Network Share** with the same username and password. Alternatively, you may want each camera to have a unique username and password.

If all cameras will use the same username and password and the Snap Server administration username and password is acceptable for access to the **VideoArchive Share**, you are ready to connect the cameras to the **VideoArchive Share**.

If you want to specify a user other than the Snap Server administrative user to enable the cameras to access the Video Archive, or if you want to control access to the **VideoArchive Share** on a per-camera basis, proceed to **Share Access Setup**.

Creating a Separate Camera User and Access to the Network Share

This section will cover setting up a separate username and password for cameras to access the Network Share VideoArchive, rather than using the Administrative username and password.

If you want to use a profile that has been defined in a Windows Domain, the Snap Server can connect to a Windows NT or AD domain. Refer to the Administration Guide for instructions on joining a Windows Domain. If the surveillance environment will be a standalone environment, then a local user will need to be created on the Snap Server.

To create a new local user, select Security from the top menu, then Local Users to create a new local user. Select the New button to create a new user.

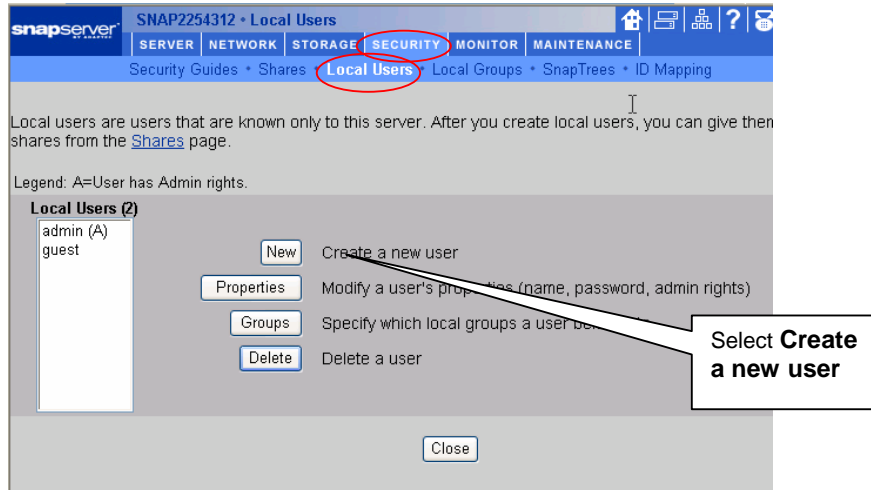

Enter the **Name, Full Name** (description), and password for the new user. Click **OK** to save this profile. This will become the username and password used to access the Network Share **VideoArchive**.

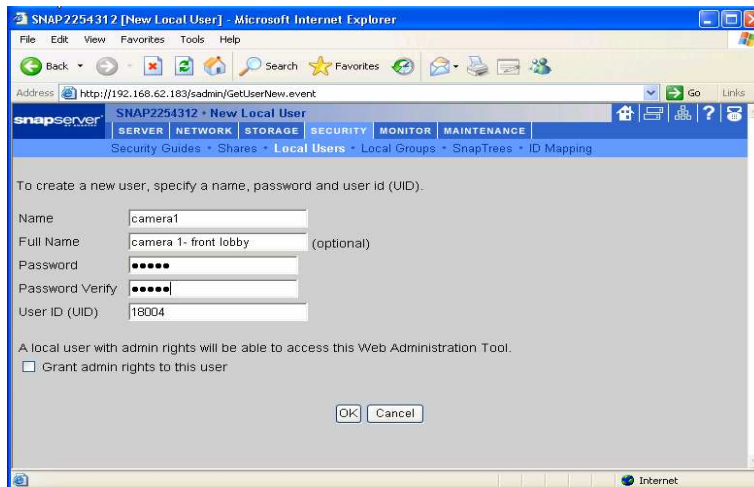

Once you click **OK** you will see the username appear in the Local Users list on the left entry list. In the example below, three camera users were created by repeating the steps above. All of these users could have the same password (recommended), or each user could have a different password.

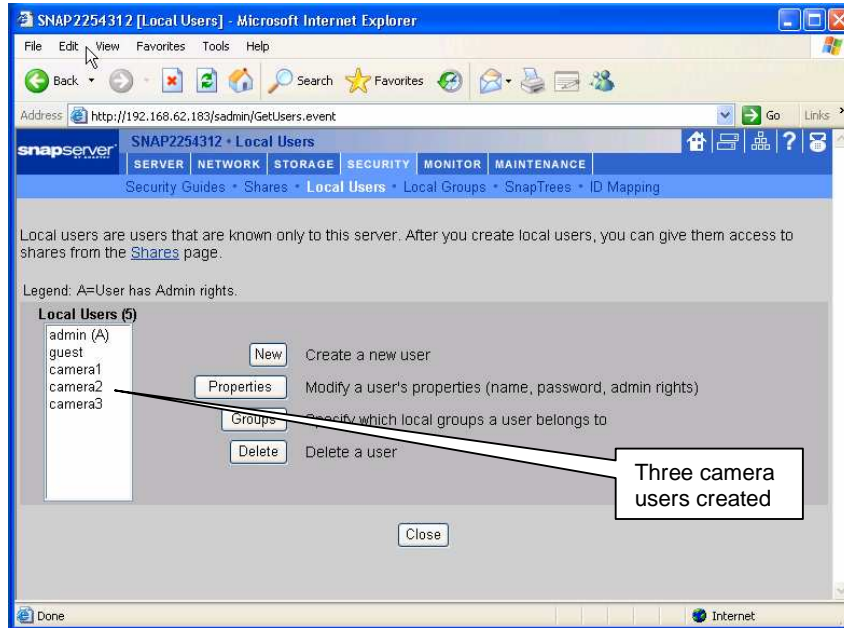

Lastly, we will configure three users and grant access to the **VideoArchive** Network Share.

With the **Video Archive** Share highlighted on the left list, select the **Access** button to enter the Share Access page.

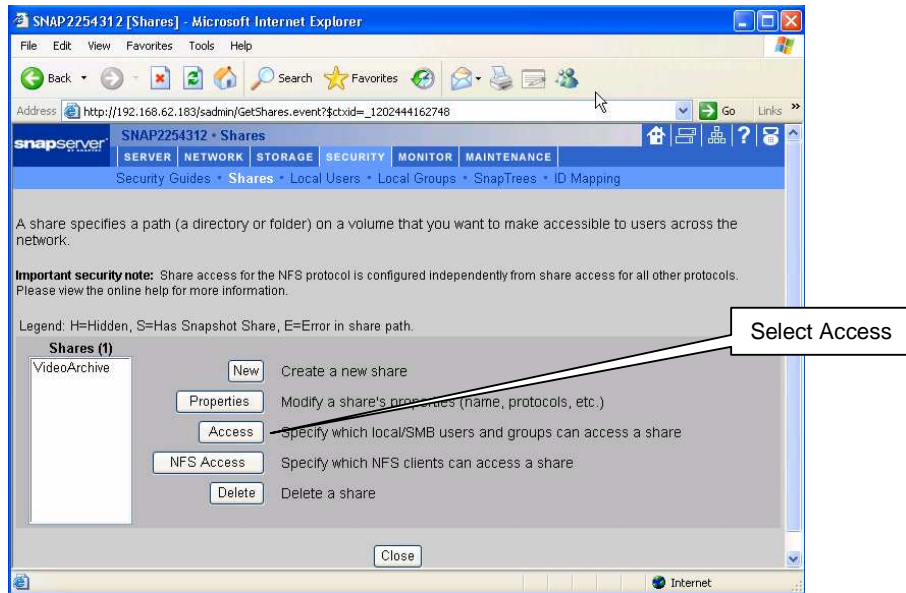

On the Share Access page, you should only leave admin full access to **VideoArchive**. Highlight each local user on the right side, select access and type **Full Access**.

Click **Add** to move the specific user over to the left list that shows which users can access the **VideoArchive** Share. Do this for each camera user you created.

Example: camera access only by using admin username and password:

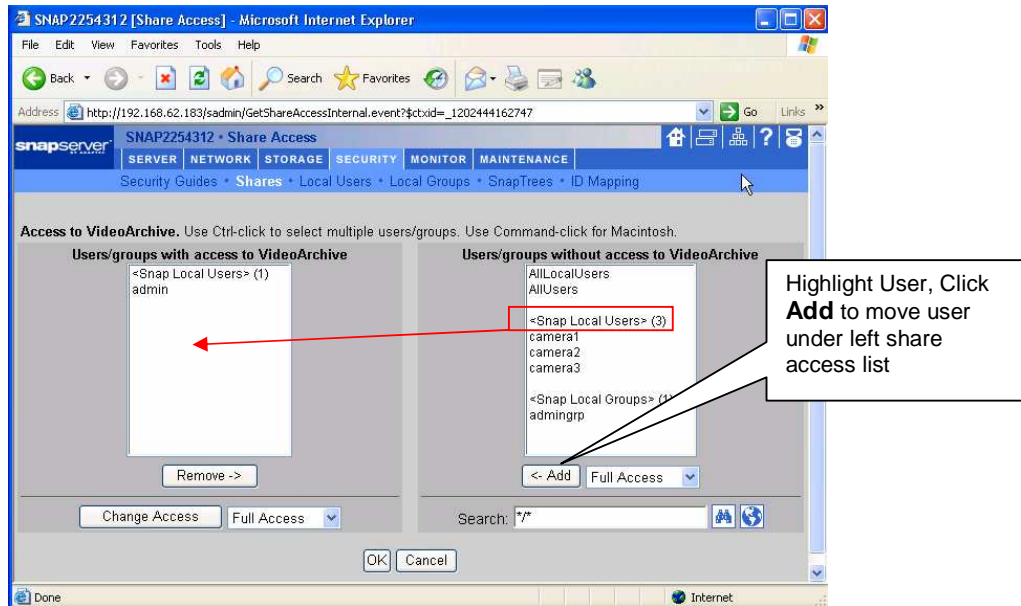

Click **OK** to save the user access to the **VideoArchive** share; the cameras can now only connect to this Share by using the admin username and password you defined for the local users.

Example: camera access by using the username and password specific to each camera:

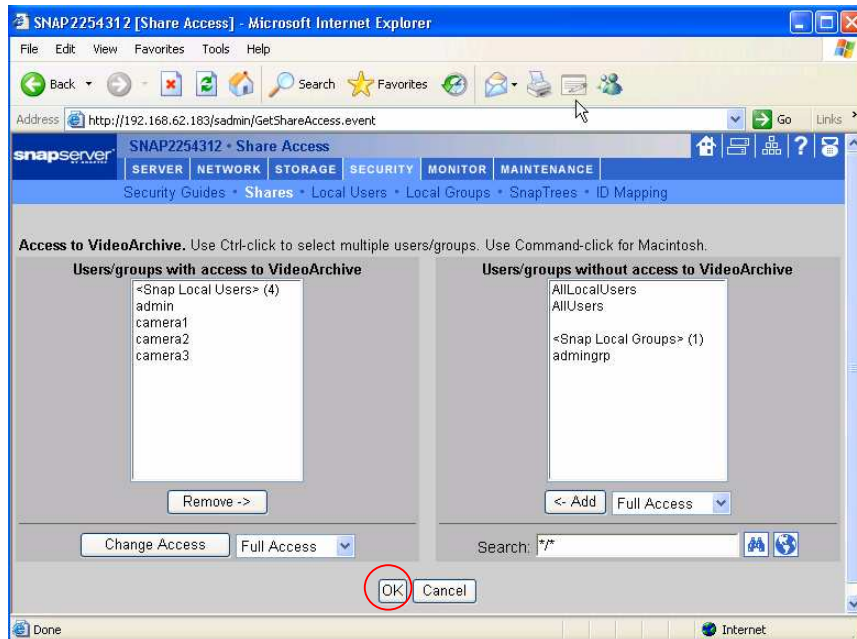

Mounting the VideoArchive Network File Share on a PC Running MxControlCenter

There are several ways to mount a File Share on a PC running Microsoft Windows.

The simplest way is to right-click on **My Computer** and select **Map Network Drive**. The dialogue box below will appear. In the **Drive** box, select the drive letter you want the PC to use to identify this Network Share.

In the **Folder** box, type the IP address and Share name of the File Share you want this PC to mount on the network, using the following format: \\<**Snap Server IP address**>\<**share name**>

Then select the link **Connect using a different user name**. Enter the desired MxControlCenter username and password into the new dialogue box.

Make sure **Reconnect at logon** is checked so the mount will occur automatically if the PC is rebooted.

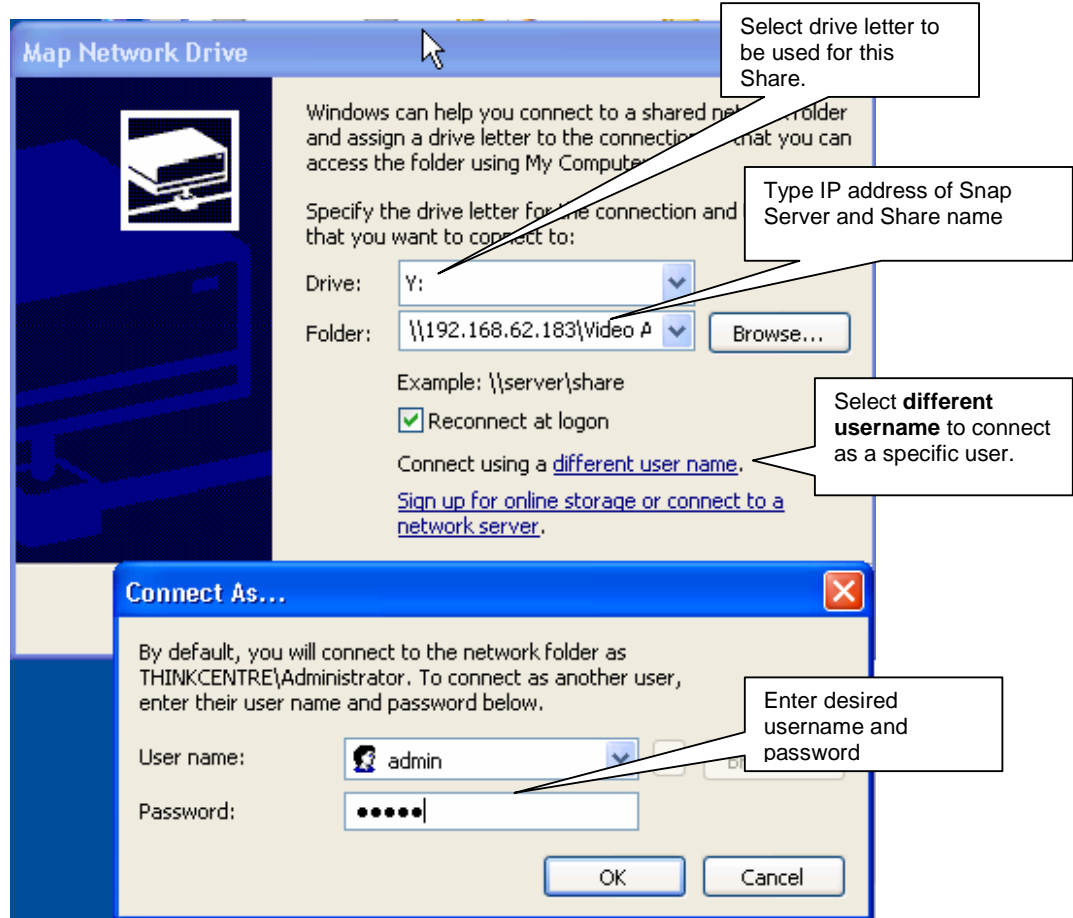

When the Share mounts on the PC you will see it listed under **Network Drives** in **My Computer**.

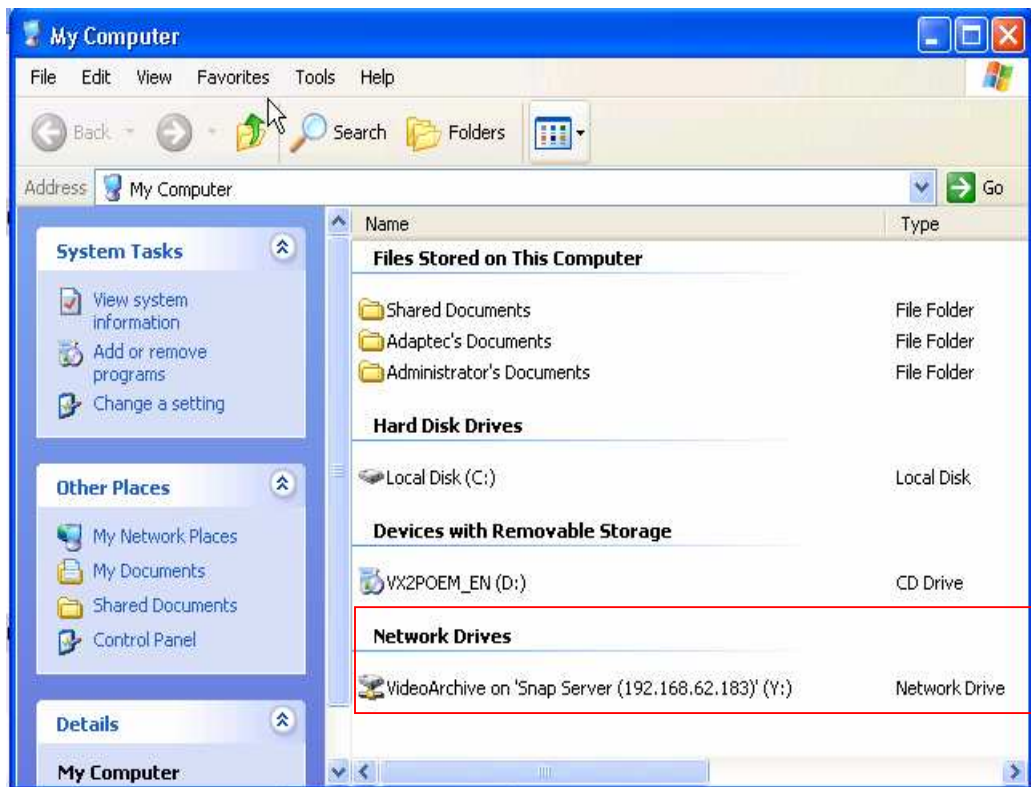

Basic Camera Setup

You will need to review the camera's documentation to familiarize yourself with how to properly install and configure the MOBOTIX Camera for the appropriate IP network. Refer to section 3.4 for specifics. For purposes of this paper a MOBOTIX M12 Camera was used, but the management interface is standard among all MOBOTIX cameras running software version MX-V3.3.2.3. To locate the proper manual visit http://www.MOBOTIX.com/eng_US/support/manuals

MOBOTIX cameras do not require any software installation. All that is required to manage them is a Web browser with JavaScript support. The camera has been set at the factory to support the Ethernet interface of the camera (10/100 Mbps or auto-sensing Gigabit Ethernet).

Connect the camera to a port on the network switch with a regular patch cable. Launch a web browser on the PC and enter the IP address printed on the camera label (e.g.10.1.0.99). If the computer does not have an IP address in the 10.x.x.x network range, you should install MxControlCenter software for Windows (see section 3.4.7 of the camera manual). Using MxControlCenter the remaining process of connecting to the camera is based on the Zeroconf/Bonjour protocol. Refer to section 3.4.7 of the camera manual for more information. If it is not possible to use MxControlCenter, you will need to temporarily set the computer to the IP address range of the camera (see section 3.4.1 of the camera manual).

Configuring External Recording and Viewing the Video Archive with MxControlCenter

MOBOTIX MxControlCenter is a free Windows application that displays and manages multiple MOBOTIX cameras on one computer. It can simultaneously display 30 cameras, each with CIF resolution at 30 fps in MxPEG format, on one standard PC with an Intel Pentium 4 3 GHz processor.

MxControlCenter can do much more than display video and audio data from MOBOTIX cameras. It is a full-featured security monitoring platform with an array of capabilities, including the ability to:

- handle camera setup
- attach external storage (your Snap Servers)
- support Time Synchronous Playback
- handle intelligent alarms
- arrange camera views on different layouts (MultiView screens)
- display cameras that are sending alarm notifications

A copy of MxControlCenter is included with all MOBOTIX cameras, but the latest version can be downloaded from the MOBOTIX website at www.MOBOTIX.com.

Install MxControlCenter from either the CD or from the MSI file download. The installer automatically creates the shortcuts selected in the installation process (desktop, start menu, etc).

When you start MxControlCenter for the first time, or if you have not yet stored a start layout with the desired video sources (i.e. MOBOTIX cameras), the **Open Video Sources** dialog will open and automatically scan the network.

Click on either of these to conduct an automatic search for cameras on the network or add them to the configuration manually

Add the file server path to allow you to search and view the video archive

Configured Video Sources are listed here

Click OK to open the Monitoring/image Control Center window

Name	Video source	Type	Version	Bonjour
mobotix-M12	192.168.62.233	M12D-Sec-D...	MX-V3.3.2.3	

The Video Sources window will let you add MOBOTIX cameras and File Servers to the MxControlCenter configuration. The Network Share on the Snap Server must be mounted on the PC where

MxControlCenter is installed. Refer to the section on mounting the Snap Server Network share on the PC running MxControlCenter for more information.

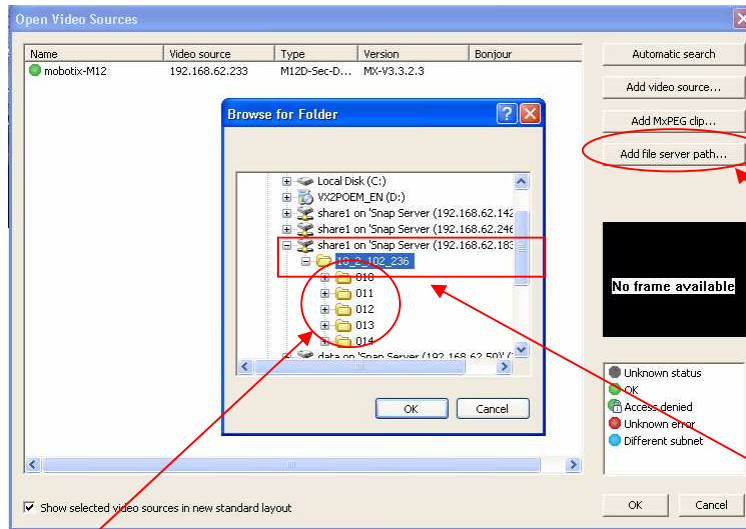

Selecting this button will open a dialogue box to allow you to choose a particular Share on the network. The Network Share on the Snap Server must be mounted on the PC where MxControlCenter is installed.

Select the Snap Server Share, then select the sub folder in the Share for a particular camera.

The actual images are stored in consecutively numbered folders.

Each Camera that mounts the Snap Server Network Share writes its own directory structure in that Share. The Directory Name the camera writes is actually the original IP address set in the camera at the factory, even if the IP address is changed for the actual on-site implementation. The image files are written in a consecutively numbered sequence of folders beneath this top-level camera directory in the format (10_2_102_236), as shown in the example above.

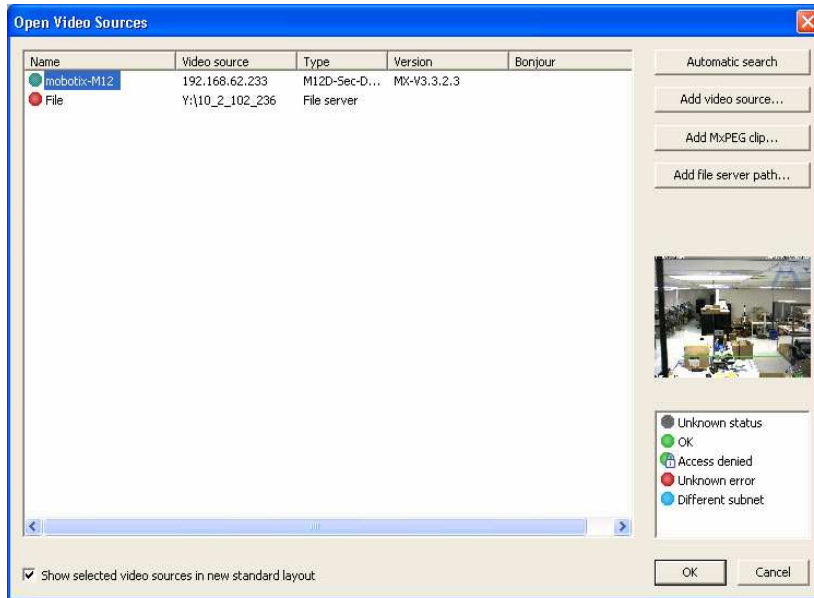

The image above shows one Camera and its associated Camera Folder (on the Snap Server Network Share) configured for MxControlCenter.

The image below shows the MxControlCenter console displaying both the Live camera image (on the left) and the Image Archive (on the right) for the same camera.



This icon indicates that control is on the live camera image (the left image).

Note: the yellow outline around the image identifies the control window.

How to Search Through the Network Video Archive Stored on the Snap Server

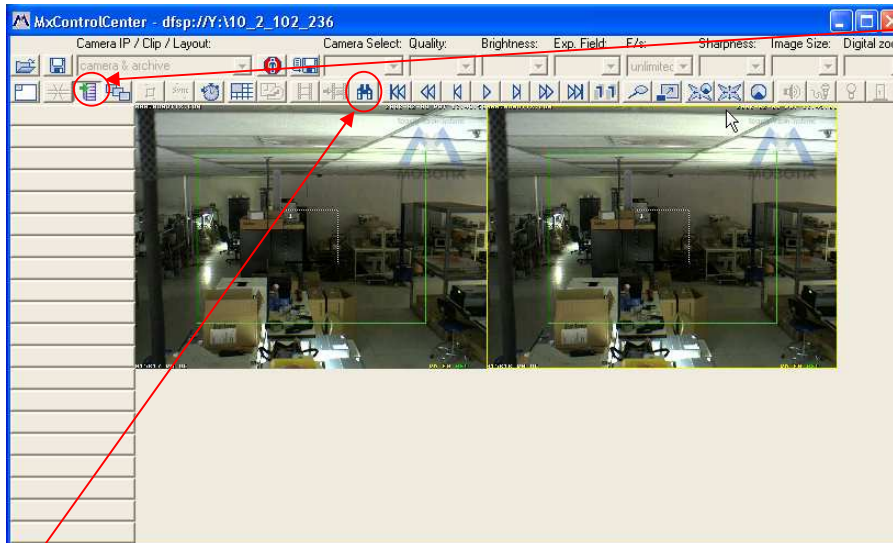

This icon indicates control is on the Archive image (the right image).

Note: the yellow outline around the image identifies the control window.

The Binocular icon is the Event Search icon. This will let you search through either the video images stored on the camera's internal ring buffer, or the video images stored in the Snap Server video archive. Let's focus on searching the video archive stored on the Snap Server

The Event Search window below shows the images stored on the Snap Server video archive. The search functions are intuitive and easy to maneuver. Refer to section 2.6.4 of the MxControlCenter manual for more search manipulation details. A few highlights relative to images stored on the Snap Server video archive are highlighted below.

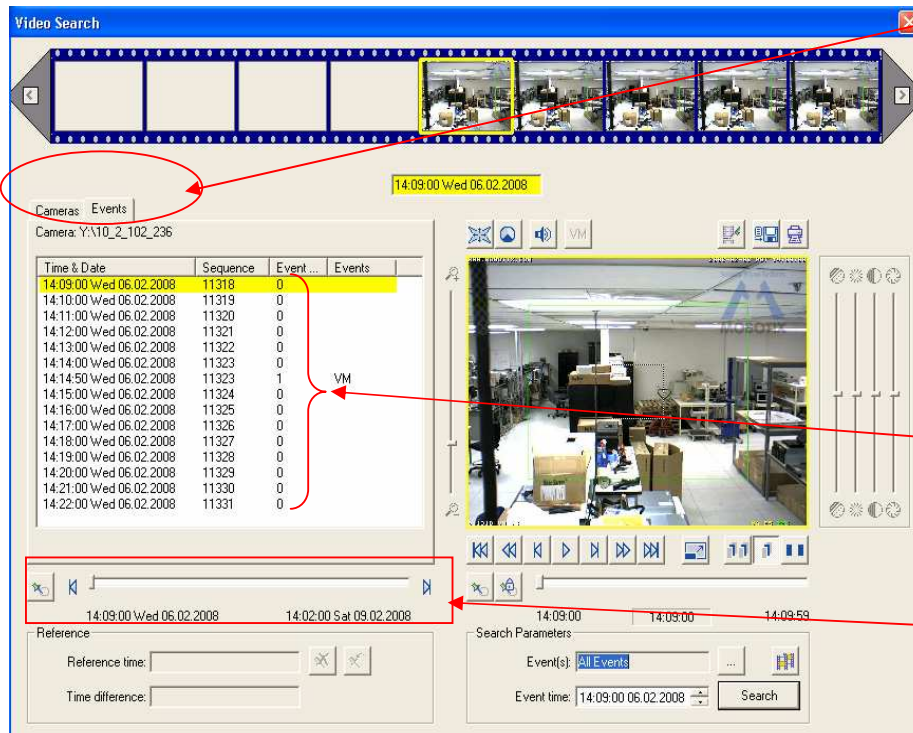

Clicking the **Events Tab** provides access to a camera's archived images. Note: The Folder ID is the Network mount point.

You can now use any of the Event search controls in this window.

Image clips stored on Video Archive are sequenced by time.

Moving this slider will move through the other clips stored in the archive.

Configuring External Recording Using the Camera's Built-in Browser Administration

Adding the Snap Server into the camera configuration as a Video Archive

This section focuses on the relevant steps for configuring the camera to establish a CIFS connection to the Network Share on the Snap Server as the Network Video Archive. This section assumes that the camera and the PC are already configured on the proper network.

Each MOBOTIX camera independently manages its own storage space in a separate folder on the Snap Server. The maximum storage space for the video archive on the Snap Server is set in the camera software (referred to as "ring buffer storage"). The camera automatically deletes old recordings to make room for new video clips, or if the allotted life time for a recording has expired. Independent of the recording mode chosen, the MOBOTIX camera first stores the recorded video clips in its internal ring buffer (see Ring Buffer Synchronization illustration below). This enables the camera to bridge network failures and maintenance of network components for a period of time, without losing images (refer to chapter 8, **Recording**, for more detail).

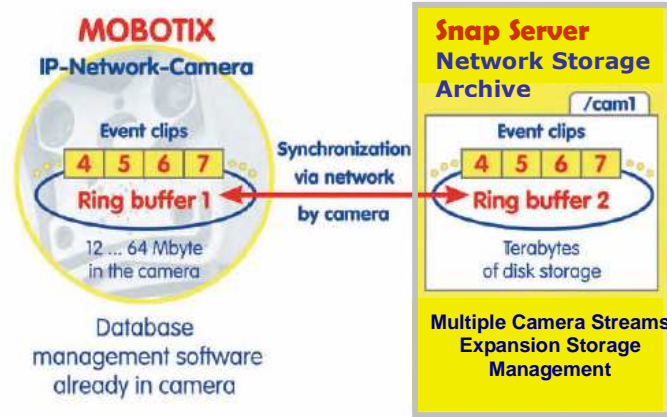

Steps for setting up Storage Archiving:

1. Launch a web browser on the PC and enter the previously assigned IP address.

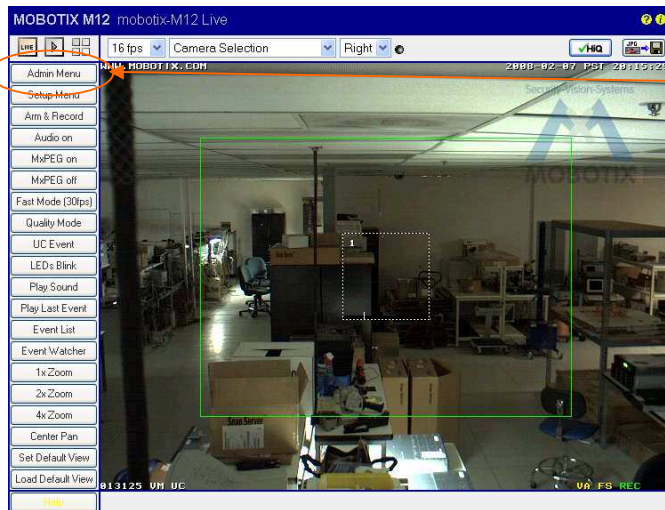

2. Once a connection has been established, click on the **Admin Menu** button to start configuring the camera. The **Admin Menu** controls all network settings (IP address, Subnet mask, DHCP, Event Storage, etc...)

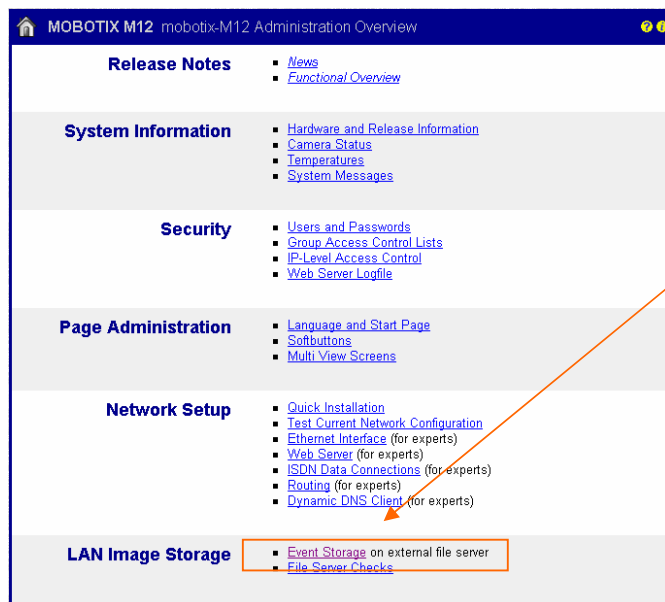

3. The administration menu of the MOBOTIX camera contains the **Event Storage** dialog for setting the network address and the maximum storage capacity on the recording PC/server.

External Event Storage

When access is established IP address will be green

Status: Currently CIFS on //192.168.62.183/VideoArchive

Available Recording Targets

- None Select this option to disable external event recording.
- NFS File Server NFS is the protocol commonly used to connect to UNIX/Linux file servers.
- CIFS File Server CIFS is the new and recommended way of accessing Windows file servers or UNIX/Linux-based file servers running samba. It also allows the camera to use Active Directory Service (ADS) and Windows Domain Controller authentication credentials when connecting to the file server.
- SMB File Server SMB is the obsolete mechanism to connect to Windows file servers. It is provided for backward compatibility only.

External Event Recording Options

File Server IP: 192.168.62.183 IP address of server. Note: The server must be reachable via the network.

Remote Directory/Share: VideoArchive Directory on the server to be mounted by the camera. Note: The server has to grant mounting rights to the camera.

Username: camera1 Username of the camera account on Windows.

Password: test1 Password of the camera account on Windows.

Storage Size: MB Unlimited Maximum size in megabytes used to store alarm images and sequences.

Time to keep: 3 Days Unlimited Maximum time to keep alarm images and sequences before removing (in days).

Number of sequences: Unlimited Maximum number of sequences to store.

Buttons: Set, Factory, Restore, Close, More

4. External File Server: Activate the CIFS option (or NFS, depending on what protocol you set in the Snap Server) as the external image archive

5. File Server IP: Enter the Snap Server's IP address or DNS name

6. Enter Remote Directory, Share Name, User Name, and password Created on the Snap Server

Never choose Storage Size as "unlimited". Set a maximum storage size to limit how much space is required on the Snap Server.

The remaining three settings establish the storage size limits, the amount of time images will be kept, and the maximum number of events to store on the Snap Server. It is usually sufficient to just set the storage size limit. Only special applications require specifying the maximum time to keep the images and the maximum number of events. Consult the MOBOTIX manual for more details.

Storage Size: Enter the maximum size (MB) the camera will use on the Snap server in this field. The factory default setting is 512 MB. When reaching the maximum storage size, the MOBOTIX camera will automatically delete the oldest files. Caution: the setting *unlimited* will create an error once the storage capacity has been reached.

Time to keep: Enter the maximum time (in days) in this field, for which the camera should keep the images on the Snap Server before deleting them. The factory default setting is unlimited. The MOBOTIX camera will automatically delete all images that are older than the maximum number of days specified.

Number of Events: Enter the maximum number of events to store on the Snap Server in this field. The factory default for this setting is unlimited. When reaching the maximum number of events, the MOBOTIX camera will automatically delete the oldest events.

To start the camera recording to the Snap Server, you must click the **Set** button to apply the settings, close the dialog, store the configuration, and reboot the camera. *Note: changed settings will only be applied after the camera has been rebooted.*

Configuring External Recording Using MxControlCenter

Adding the Snap Server into the camera configuration as a Video Archive

If the installer uses the MxControlCenter to add cameras, the Snap Server network Share can also be configured with the camera setup. The steps to achieve this are as follows:

1. Once a camera has been configured, select the **Edit Camera Configuration** icon from the function button row in the main window of the MxControlCenter,

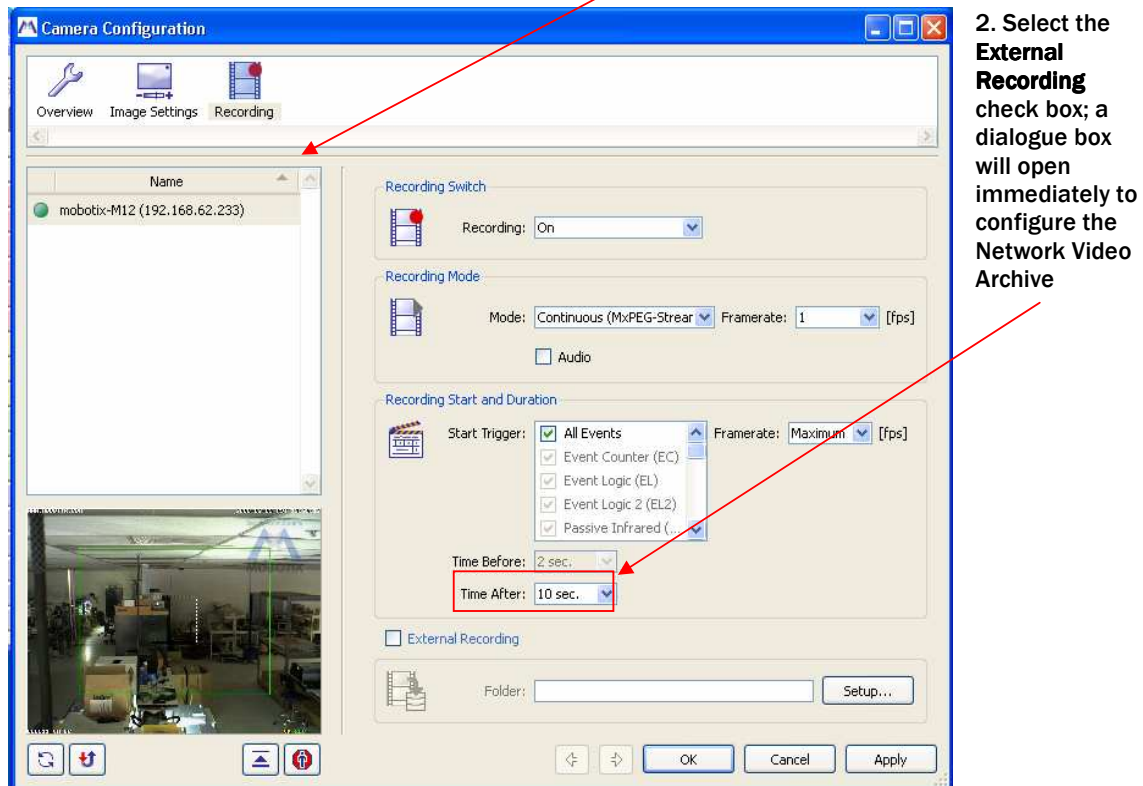
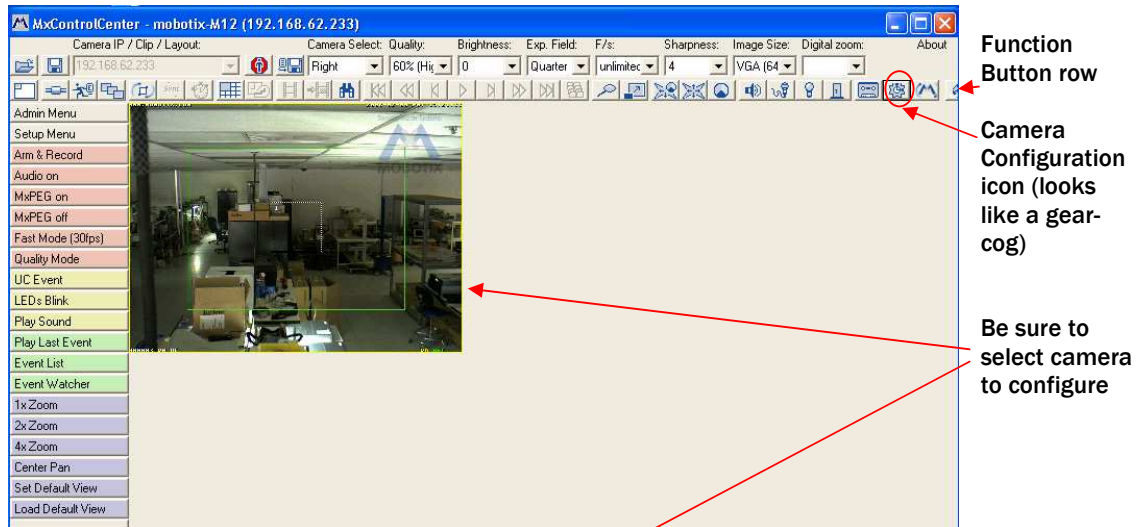

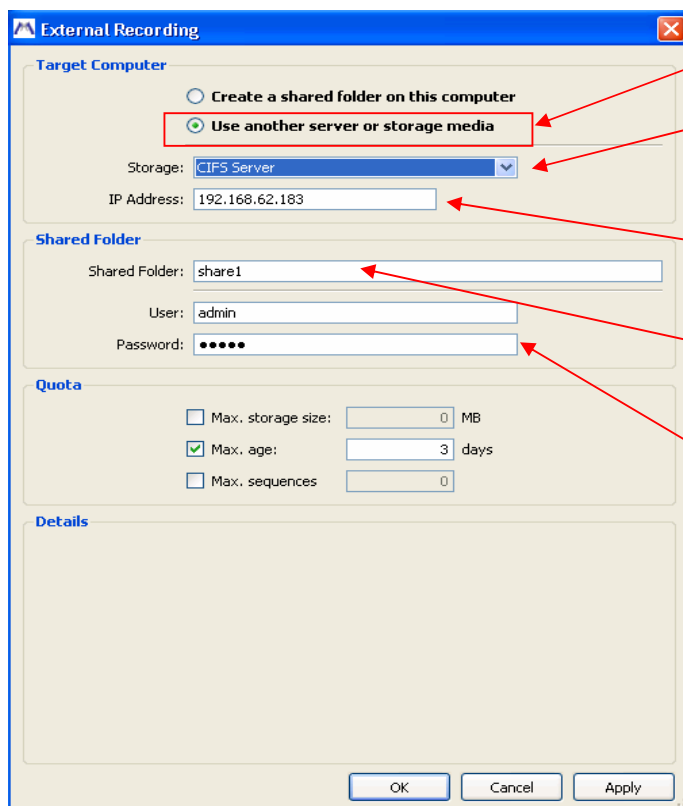

3. Select **Use another server or storage media**

4. Choose the type of server to which the cameras will connect. Snap Server will be either CIFS server or NFS Server

5. Enter the IP address of the Snap Server set up as the archive

6. Enter in the Share Name previously established on the Snap Server (default is share1). To access the Snap Server, you will need to enter the username and password of the camera user or admin allowed to access the Snap Server.

Quota section is set as previously described in Table1

Choose storage size as a second limit

When you click **Apply**, the **Details** section of this screen will tell whether you have set up the path correctly.

If you get this message:  File Sharing is set up correctly. in the **Details** portion of the windows, the path is set up correctly. Click **OK** to proceed to the next camera.

In Conclusion

Overland Storage Snap Server storage systems offer a cost effective and powerful networked storage solution for MOBOTIX Cameras. Together, Overland Storage and MOBOTIX offer a complete video surveillance solution. Snap Servers offer high performance throughput and provide right-sized storage – from 250GB desktop units to 19-inch rackmount systems that scale to 88TBs, to fit a variety of budgets and environments. Snap Servers integrate easily with MOBOTIX Cameras and the surveillance infrastructure offering to provide ease-of-use, rock-solid reliability, RAID data protection, and multi-unit management, as well as local backup and video file replication for added protection of your critical video files.