

2N[®] EASYGATE GSM GATEWAY



Wireless
Modules
by Siemens
embedded



- Dramatic cost saving
- Connection to GSM Networks
- Voice, Data and SMS transmission
- Analogue FAX (optionally)
- For PBX or Phone sets
- FSK CLIP

Technical Support
FREE
OF CHARGE

Dear customer,

Let us congratulate you on having purchased the EasyGate system. This new product has been developed and manufactured to provide the maximum utility value, quality and reliability. We hope you will be fully satisfied with this GSM gateway for a long time. Therefore, use your EasyGate for purposes it has been designed and manufactured for, in accordance herewith.

The manufacturer reserves the right to modify the product in order to improve its qualities.

Safety Precautions



Do not switch on EasyGate in the vicinity of medical apparatuses to avoid interference. The minimum distance of the antenna and pacemakers should be 0.5 m.



Do not switch on EasyGate aboard of a plane.



Do not switch on EasyGate near petrol stations, chemical facilities or sites where explosives are used.



Any mobile telephone use prohibition based on RF energy radiation applies to EasyGate too.



EasyGate may disturb the function of TV sets, radio sets and PCs.



Warning! EasyGate contains components that can be swallowed by small children (SIM card, antenna, etc.).



The voltage value mentioned on the adapter may not be exceeded. If you connect EasyGate to another power supply, make sure that the voltage value is in the acceptable range.



When your EasyGate comes to the end of its operational life, dispose of it in accordance with applicable regulations.

User Manual Versions

Version	Amendments to Earlier Versions
1.00	<ul style="list-style-type: none">•The User Manual applies to EasyGate FW Version 1.00D.
1.01	<ul style="list-style-type: none">•New parameter for dial tone setting.•LED indications updated.•The User Manual applies to EasyGate FW Version 1.00E
1.02	<ul style="list-style-type: none">•Default setting for dial tone is continuous tone now.•The User Manual applies to EasyGate FW Version 1.00F
1.03	<ul style="list-style-type: none">•New function: tariff metering with 16 or 12 kHz pulses.•New function: call connect and disconnect signaling by 16 or 12 kHz pulses.•The User Manual applies to EasyGate FW Version 1.00G
1.04	<ul style="list-style-type: none">•Continuous dial tone.•Chapter 2.2 modified.•SMS input parameters added.
1.05	<ul style="list-style-type: none">•GSM gateway name modification.
1.06	<ul style="list-style-type: none">•Analogue FAX support. (optionally)
1.07	<ul style="list-style-type: none">•Analogue Modem support, Network directing services support, Quadband ver.

Upgrade

The manufacturer continuously meets customer requirements by improving the firmware. For the latest EasyGate processor firmware, programming tool and User Manual see www.2n.cz. For a detailed description of the EasyGate firmware upgrade refer to the section devoted to the PC programming tool.

Packing List

An **EasyGate** delivery contains the following items:

Item	Number of Pieces
EasyGate	1 pc
Antenna for direct connection	1 pc ¹⁾
Magnetic Antenna with coax cable	1 pc ¹⁾
Supply adapter	1 pc
Telephone cable	1 pc
PC-connection serial cable	1 pc
SMS sending input connector	1 pc
Dowels	2 pcs
Bolts	2 pc
CD-ROM with User Manual and software	1 pc ²⁾
Quick Installation Guide + mounting pattern	1 pc
Warranty certificate	1 pc

Notes:

1) *The delivery includes an antenna to be connected directly to the EasyGate SMA connector. An antenna with a cable should be used when GSM signal is poor or in case of interference with other devices.*

2) *Enclosed software:*

- *EasyGate PCManager*
- *EasyGate SMSgateway for easy SMS sending and receiving.*
- *EasyGate Driver for PC*
- *User Manual in pdf format*
- *Lists of AT Commands for SIEMENS GSM modules used*

CONTENTS

1. EASYGATE PURPOSE	1
1.1. BASIC FUNCTIONS.....	1
1.2. ADVANTAGES OF EASYGATE USE.....	1
2. INSTALLATION	2
2.1. PROPER LOCATION	2
2.2. EXTERNAL ANTENNA CONNECTION.....	3
2.3. SIM CARD INSTALLATION.....	3
2.4. CONNECTOR DESCRIPTION	4
2.5. TELEPHONE LINE CONNECTION.....	4
2.6. POWER SUPPLY CONNECTION	4
2.7. SMS SENDING INPUT CONNECTION.....	4
2.8. PC CONNECTION	5
3. EASYGATE STATUS INDICATION.....	6
3.1. INDICATION LEDS.....	6
3.2. TELEPHONE LINE TONES	6
4. SIM CARD PIN PROTECTION.....	8
4.1. PIN ENTERING BY PCMANAGER.....	8
4.2. PIN ENTERING VIA TELEPHONE LINE	8
4.3. AUTOMATIC PIN ENTERING.....	8
5. VOICE FUNCTION.....	9
5.1. OUTGOING CALL	9
5.2. INCOMING CALL.....	9
5.3. AUTOMATIC CALL ("BABYCALL").....	10
5.4. TARIFF PULSES 16 OR 12 KHZ.....	10
5.5. CONFIGURATION OF NETWORK SERVICES.....	10
5.6. CALL FORWARDING	11
5.7. CALL WAITING	12
5.8. CALL HOLD.....	12
6. FAX AND DATA FUNCTION	14
6.1. SENDING FAX MESSAGE OR MODEM CONNECTION TO AND FROM GSM.....	14
6.2. SUPPORTED FAX AND DATA PROTOCOLS.....	15
7. SMS SENDING INPUT	16
8. COM – SERIAL INTERFACE.....	17
8.1. PROGRAMMING, MONITORING	17
8.2. CSD PC-PC DATA TRANSMISSION.....	17
8.3. CSD OR HIGH-SPEED GPRS DATA CONNECTION TO INTERNET	18
8.4. SMS SENDING AND RECEIVING	18
8.5. COMBINATION OF COM TRAFFIC WITH VOICE CALLS	18
8.6. LIST OF SUPPORTED AT COMMANDS.....	19
9. EASYGATE PARAMETER PROGRAMMING	20
9.1. TELEPHONE LINE BASED PROGRAMMING	20
9.2. PC BASED PROGRAMMING.....	21
9.3. PARAMETER TABLES	24
10. TROUBLESHOOTING	37
11. LIST OF ABBREVIATIONS	38
12. TECHNICAL PARAMETERS.....	39

1. EasyGate purpose

1.1. Basic Functions

- The primary purpose of EasyGate is to transmit voice between a GSM network and an attached FXO-interface terminal (PBX, telephone, answering machine, etc.).
- You can establish data connections (GPRS, CSD) and send/receive SMS using EasyGate in combination with a PC and appropriate software.
- You can send an SMS to a pre-programmed number using the SMS sending input.
- Analogue fax transmission on some models.

1.2. Advantages of EasyGate Use

- **Call cost cutting** – by forwarding GSM calls to EasyGate you save a lot on PSTN – GSM calls.
- **Easy installation** – EasyGate is designed for immediate use without programming.
- **You get all you need in the delivery** – your EasyGate delivery contains all you need to operate the system (the power supply adapter, telephone cable, PC serial cable, SMS input connector, CD-ROM with software).
- **Solution for sites without telephone lines** – such as mountain chalets, exhibitions, conferences, etc.
- **CLIP** - EasyGate is equipped with the FSK-based CLIP feature, so if a terminal capable of receiving the CLIP is used you know the caller's number.
- **Quick data connection** – EasyGate transmits data using the high-speed GPRS connection (GPRS class 10, max. 85.6 kbps).
- **SMS sending input** – simply send an SMS to a pre-programmed number by closing the contact. Recommended for easy supervision, simple securing, etc.
- **Radiation hazard minimization** – you are not exposed to a direct effect of the antenna RF electromagnetic field while telephoning as opposed to mobile telephones.
- **Full GSM coverage** - EasyGate is available in the following versions: dual-band (900 and 1800MHz), tri-band for European markets (900, 1800 and 1900MHz), tri-band for the American market (850, 1800 and 1900MHz) and quadband (850, 900, 1800, 1900MHz).

2. Installation

2.1. Proper Location

- EasyGate is designed for vertical mounting on suspension holes (use the mounting pattern). This position is the best for signal reception because a vertical antenna is used. EasyGate can be operated in the horizontal position too where the GSM signal is good.
- Install EasyGate with respect to the GSM signal strength – check the signal strength using the PCManager.
- Place EasyGate out of range of sensitive devices and human bodies for electromagnetic interference reasons.
- For the allowed range of operating temperatures refer to the “*Technical Parameters*”.
- It is impossible to operate EasyGate on sites exposed to direct solar radiation or near heat sources.
- EasyGate is designed for indoor use. It may not be exposed to rain, flowing water, condensed moisture, fog, etc.
- EasyGate may not be exposed to aggressive gas, acid vapours, solvents, etc.
- EasyGate is not designed for environments with high vibrations such as means of transport, machine rooms, etc.

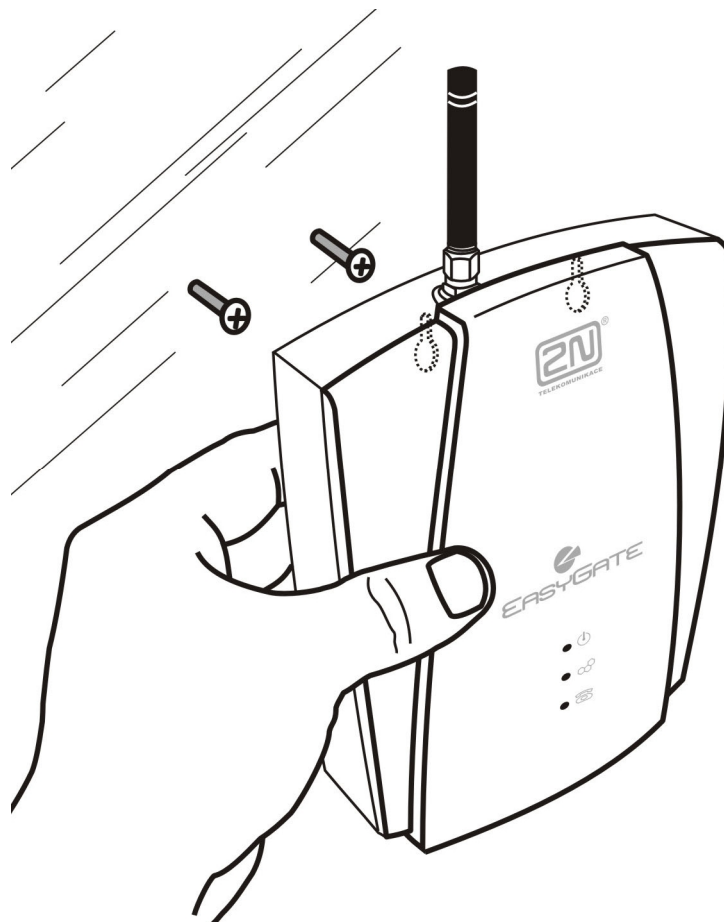

2.2. External Antenna Connection

Screw the antenna enclosed into the SMA antenna connector. Tighten the antenna connector gently with your hand - never use wrenches!

The antenna enclosed has a sufficient gain for trouble-free operation in normal conditions. If the GSM signal is poor or you want to place your antenna separately from EasyGate, you can use an antenna with an SMA-connector terminated cable. The antenna should be mounted vertically.

The Antenna shall be located within the same building as the main equipment.

For antenna and cable parameters see the “*Technical Parameters*”.

2.3. SIM Card Installation

Make sure that the GSM provider’s SIM card is compatible with the GSM network supported by your EasyGate version.

Open the SIM card holder on EasyGate’s backside, insert the SIM card and close it. Select the required GSM provider and SIM card services, such as call forwarding, call barring, preferred networks, SMS service centre, etc. in your mobile phone before inserting your SIM card in EasyGate.

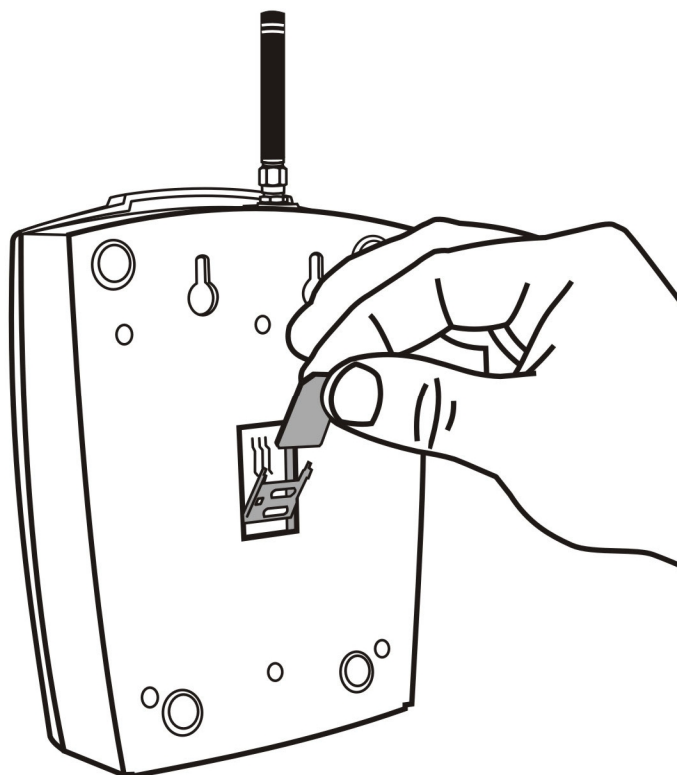

2.4. Connector description

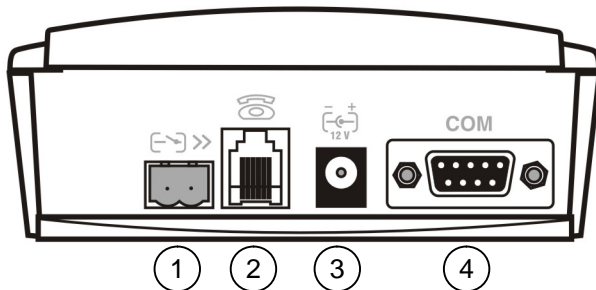

- ① SMS sending input
- ② Telephone line
RJ 12, 6/2
- ③ Power supply connector
DC Jack 2,1mm
- ④ RS232C serial line
D-Sub 9 pins

2.5. Telephone Line Connection

2.5.1. PBX Connection

Connect EasyGate to a free CO line of your PBX. Configure your PBX in such a manner that GSM outgoing calls are routed to EasyGate.

EasyGate is equipped with the FSK-based CLIP function. If your PBX is able to process the caller's ID, you are advised to enable this function.

2.5.2. Telephone Set (Answering Machine, Coin Telephone Station) Connection

You can connect a standard telephone, answering machine or any other FXO-interface terminal to EasyGate. Optionally you can connect analogue fax (special model of EasyGate).

EasyGate is equipped with the FSK-based CLIP and so it is advantageous to connect a terminal that is able to display the CLI.

2.6. Power Supply Connection

EasyGate is fed with 10-16V DC. Where a source other than the included power supply adapter is used, the voltage range and polarity shown on the EasyGate power supply connector have to be maintained.

Do not activate the power supply until the antenna is connected to EasyGate to avoid the GSM module damage.

2.7. SMS Sending Input Connection

You have got a special connector for easy connection to EasyGate. The connector is equipped with screwing clamps to connect wires leading to a switching contact (device to be monitored). The other connector end can be connected to the respective EasyGate panel connector.

The input is designed for the switching contact connected between the input pins. The input is activated by contact closing (pin interconnection).



A transistor switch or logic signal can be used too. The pin near the telephone line connector is connected to GND of the device the second one is active. Please, respect the loop current polarity. The input is over-voltage protected (up to +12V DC).

2.8. PC Connection

You have got a serial cable for PC connection. It is a modem cable where all of the 9 pins are 1:1 interconnected – in case you wanted to use another, longer cable. Make sure that a longer cable works properly to avoid errors at high transmission rates.

3. EasyGate Status Indication

3.1. Indication LEDs

Name	Meaning
Power supply 	<ul style="list-style-type: none"> • Light = EasyGate is powered. • Flashes once in 2s = HW error, contact the manufacturer.
GSM network 	<ul style="list-style-type: none"> • Light = registered to GSM • Flashes once in 1s = not registered, SIM card inserted • Flashes once in 3s = not registered, SIM card not inserted • Flashes 4 times quickly = enter your PIN • Flashes 8 times quickly = enter your PUK • Flashes quickly continuously = all functions are blocked. Your SIM doesn't correspond to the GSM operator lock
Telephone line 	<ul style="list-style-type: none"> • No light = standby • Flashes quickly = seized line or ringing • Light = call • Flashes once in 3s = data connection in progress On FAX models: <ul style="list-style-type: none"> • Flashes 2 times then pause = fax connection in progress; after power on signalize need of FW upgrade. • Flashes 3 times then pause = fax connection in progress

3.2. Telephone Line Tones

3.2.1. Operational Tones

The GSM gateway sends tones to the telephone line to indicate the line status. The tone frequency is 425 Hz.

Dial tone: continuous or morse A : — —

- EasyGate is registered to GSM network and ready to receive dialing.

Ringing tone: — — — — — —

- The called subscriber's telephone is ringing.
- The GSM network transmits this tone.

Busy tone: — — — — —

- The busy tone is transmitted in any of the following cases:
 - § The SIM card has not been installed.
 - § EasyGate is logged-out.
 - § EasyGate is logged-in to a foreign network but roaming is disabled.

- § The called number has too many digits (more than 30).
- § The called number is barred.
- § The called subscriber line is busy.
- § The called subscriber has hung up (disconnection).

Dialing end signaling: –

- Dialing reception has been terminated. Connection is being established.

PIN tone: -----

- Enter the PIN code.
- This tone is transmitted upon power up if the PIN has to be entered manually.

PUK tone: -----

- Enter the PUK code.
- This tone is transmitted upon repeated wrong PIN entering attempts. SIM card is blocked.

3.2.2. Programming Mode Tones

Tones confirming/refusing the values entered are transmitted during telephone line based programming. Each tone has a different melody.

Confirmation: 

- Confirms that the service password or parameter number entered is correct and has been accepted.

Refusal: 

- Incorrect parameter number;
- Incorrect parameter value
- Transmitted when a parameter is cancelled with a .

Saving: 

- Parameter value entered is correct and has been saved.

4. SIM Card PIN protection

If a SIM card is PIN-protected and the PIN is not programmed in EasyGate, GSM LED indicates the state and the PIN tone is transmitted on telephone line.

4.1. PIN Entering by PCManager

Like other parameters, the PIN code can be entered using a PC programming tool. The PIN will be entered automatically upon next EasyGate power up.

4.2. PIN Entering via Telephone Line

To enter the PIN via a telephone line using the DTMF:

1. Hook off the telephone, you can hear the PIN tone.
2. Enter the PIN using the DTMF; to cancel the wrong PIN hang up before sending a .
3. To confirm enter a .
4. If you hear the busy tone in a while (a few seconds), you have entered the PIN correctly. Hook on and wait for registering to the GSM network.
5. If you hear the PIN tone again in a while, you have entered a wrong PIN. Re-enter the PIN.
6. If you hear the PUK tone in a while, you have entered a wrong PIN and the SIM card is blocked. Use the mobile phone to unblock the SIM card.

A correctly entered PIN is stored in EasyGate's memory as if you had programmed it using the PCManager. The PIN will be entered automatically upon the next EasyGate power up.

4.3. Automatic PIN Entering

You need not enter the PIN upon power up if it is stored in EasyGate – it is entered automatically. This function is convenient in case of power failure; EasyGate is operable in a short time after power recovery without any intervention by the operating staff.

Caution! One PIN entering option is exhausted by the attempt to enter the PIN automatically upon SIM card or PIN change. If wrong, the automatically entered PIN is cleared from the internal memory to avoid another false attempt upon next power on. There are still two manual PIN-entering attempts after such unsuccessful automatic entering. To prevent the unsuccessful automatic PIN entering, delete or program properly the EasyGate PIN using the PCManager in the case of SIM card change.

5. Voice function

Outgoing and incoming call establishing procedures for an analog telephone are described for illustration. The procedures are the same for the EasyGate-PBX connection, just remember to program call routing to EasyGate properly. Check EasyGate's function by connecting a telephone before.

Suppose that a SIM card has been inserted, the PIN code entered or not required, the antenna connected and EasyGate registered to GSM network – the GSM network LED is permanently on and you can hear the dial tone upon off-hook.

5.1. Outgoing Call

1. Hook off the telephone, you can hear the dial tone and the Line LED starts flashing.
2. Dial the required GSM subscriber number. Since EasyGate receives tone dialing by default, select the DTMF mode. If your telephone transmits pulse dialing only, program EasyGate to receive pulse dialing. The delay between digits to be dialed may not exceed 5 s (programmable parameter). The number is evaluated as complete and transmitted to the GSM network after this timeout.
3. A short delay follows the last-dialed digit for EasyGate to await further dialing. Then, the dialing end is signaled and connection is established.
4. If the called subscriber is available, you can hear the ringing tone. If not, you can hear the busy tone or any of the GSM provider's messages.
5. When the called subscriber answers the call, a call is established. The Line LED is permanently on during the call.
6. Hang up to terminate the call. The Line LED goes off. If the called subscriber is the first to hang up, you can hear the busy tone and hang up.

5.2. Incoming Call

1. Ringing signals an incoming call. The Line LED flashes during ringing. If programmed so, EasyGate transmits the CLIP by FSK between the first and second rings. Advanced telephone sets are able to display the CLI.
2. Hook off the phone to establish the call. The Line LED is permanently on during the call.
3. Hang up to terminate the call. The Line LED goes off. If the called subscriber is the first to hang up, you can hear the busy tone and hang up.

5.3. Automatic Call ("BabyCall")

If the BabyCall function is enabled, a pre-programmed period of time is counted down after off-hook. If you do not start dialing within this timeout, EasyGate signals dialing end and starts establishing a call to the pre-programmed number automatically – from now on EasyGate behaves as if a standard outgoing call had been established. Any dialing during the BabyCall timeout cancels this function and a standard outgoing call can be made.

5.4. Tariff pulses 16 or 12 kHz

EasyGate has tariff pulse transmitter. You can use tariff pulses for outgoing call pricing. EasyGate offer pseudotariff only – tariff metering doesn't correspond to real price of call, tariff pulses are transmitted according to programmed parameters and call duration. You must program specific parameters in call table to set tariff metering for different prefixes of dialed numbers.

You can also program EasyGate to transmit tariff pulses as call connect/disconnect signaling if your PBX cannot receive telephone line polarity change signaling.

5.5. Configuration of network services

EasyGate provides some of network services to improve possibility of usage. The configuration is done by standard Star-Hash codes you can know from mobile phones.

To configure these services:

7. Hook off the telephone, you can hear the dial tone.
8. Enter the Star-Hash code described below.
9. Wait for information tone. You may wait about 3 seconds.
10. Hook on.

Information tones:

Confirmation - OK: 

- Confirms that the service was configured correctly.

Confirmation - bad: 

- Service was not correctly configured
- Service isn't activated by your provider

Confirmation - service activated: 

- Confirms that the service was configured correctly and the service is activated.

Confirmation - service deactivated: 

- Confirms that the service was configured correctly and the service is deactivated.

5.6. Call forwarding

For forwarding activation you must specify <Telephone number> the calls will be forwarded to. You may specify <Call type>, if you want to forward specified call type only. You may specify <Delay time> in seconds for forwarding if no answer too.

Description of <Call type> field codes:

Voice:

Data:

Fax:

5.6.1. Call forwarding unconditional

If activated, incoming calls will be always forwarded to the configured telephone number.

Activation for all call types:

<Telephone number>

Activation for selected call type:

<Telephone number> <Call type>

Deactivation:

Status check:

5.6.2. Call forwarding if busy

If activated, incoming calls will be forwarded to the configured telephone number if there is call in progress on EasyGate.

Activation for all call types:

<Telephone number>

Activation for selected call type:

<Telephone number> <Call type>

Deactivation:

Status check:

5.6.3. Call forwarding if no answer

If activated, incoming calls will be forwarded to the configured telephone number if incoming call isn't answered during specified timeout. Default timeout is 20 seconds.

Activation for all call types:

<Telephone number>

Activation for selected call type:

<Telephone number> <Call type>

Activation for all call types and specified delay time:

6 1 <Telephone number> <Delay time>

Activation for selected call type and specified delay time:

6 1 <Telephone number> <Call type>
<Delay time>

Deactivation:

6 1

Status check:

6 1

5.6.4. Call forwarding if not accessible

If activated, incoming calls will be forwarded to the configured telephone number if your EasyGate is not accessible in the GSM network.

Activation for all call types:

6 2 <Telephone number>

Activation for selected call type:

6 2 <Telephone number> <Call type>

Deactivation:

6 2

Status check:

6 2

5.7. Call waiting

If the call waiting is activated the incoming call isn't refused if there is call in progress on EasyGate. If there is the other incoming call during connected call it will be indicated by tone. See 5.8. for multiple calls management.

Activation:

4 3

Deactivation:

4 3

Status check:

4 3

5.8. Call hold

Check if your network supports the service before you use it.

This service relates to Call waiting described in 5.7. If there is call waiting on the line, you have more possibilities what to do. Every action is made by FLASH and DTMF code:

To terminate all held calls, or reject waiting call dial:

R **0**

To terminating active call and accept the held or waiting call dial:

R **1**

To place the active call on hold and accept the held or waiting call (switching between two calls) dial:

R **2**

To place all held calls to active calls and set up conference call dial:

R **3**

To connect the two calls (active and held) and disconnect the EasyGate from both calls dial:

R **4**

6. FAX and Data function

Only EasyGate with fax converter supports fax and data functions.

6.1. Sending fax message or modem connection to and from GSM

6.2.1. GSM fax and Data connection

EasyGate with fax converter has ability to send and receive GSM fax messages using analogue fax Group 3 connected to telephone line FXS. The fax communication service must be registered with your GSM operator. It is possible to establish data connection using analog modem connected to FXS line. **It is useful for devices with build-in modem, without possibility to use serial line.** The data communication service must also be registered with your GSM operator.

6.2.2. Sending a fax message to GSM and modem connection through GSM

It is necessary to dial before destination number code ***01*** for fax call or ***02*** for data call. This code is used to inform the Gateway, that the call is a fax or data call.

6.2.3. Receiving a fax message from GSM

It is recommended to activate separate fax number on your SIM card – **multinumbering scheme**. Fax messages must be routed to fax number, data call to data number. Incoming fax, data and voice calls will be than automatically recognized. It is possible to set ring pattern for fax and data call, different from the pattern for voice call.

If the fax or data number is not activated, the call from analogue network routed to your GSM number is not detected as fax or data call and is routed via the analogue channel of GSM network and the connection is not successful. In this case it is possible to set the gateway using DTMF commands using device connected to FXS line. These commands can be used for data and fax routing to FXS line or serial line.

DTMF codes for fax receive:

- ***9900#** Reset of all following settings for fax receive
- ***9901#** The next call is fax, suspended after receiving call or *9900#
- ***9902#** Fax routed to FXS, inactivate *9900# or device reset +
- ***9903#** Fax routed to COM, inactivate *9900# or device reset +

DTMF codes for data receive:

- ***9800#** Reset of all following settings for data receive
- ***9801#** The next call are data, suspended after receiving call or *9800#
- ***9802#** Data routed to FXS, inactivate *9800# or device reset +
- ***9803#** Data routed to COM, inactivate *9800# or device reset +

Commands marked + are used to set parameters, which can be set permanently in configuration program (PCManager). Using DTMF commands has higher priority, than setting in configuration program, but is valid only till reset of gateway or inactivating command.

Setting for the next call is only alternative solution, which is not able to substitute using of multinumberig scheme (e.g. when unexpected voice call is incoming before the fax or data call, this solution disables to receive it).

6.2. Supported fax and data protocols

6.3.1. Supported fax protocols

The gateway supports connection of analogue Fax Group 3 using protocols V.29, V.27 and V.27ter. Maximal data rate is 9,6kbps. The maximal data rate is strongly dependent on line quality, which is tested on the beginning of connection, to avoid data errors. The fax service is available up to field strength -90dBm.

6.3.1. Supported data protocols

The gateway supports connection of analogue modem using protocols V.34, V.32bis, V.32, V.22bis, V.22, Bell 212A and Bell 103. Maximal data rate is 56kbps. For connection between two modems is the data rate limited by the CSD data rate in GSM network, the maximum is 14,4kbps.

Higher data speed could be useful only for GPRS connection. The maximal data rate is strongly dependent on line quality, which is tested on the beginning of connection, to avoid data errors. The data rate for GPRS connection is limited by actual speed of GPRS transfer in GSM network too. This speed is often affected by network load.

7. SMS Sending Input

This universal input is intended especially for reporting alarm or error statuses of any equipment provided with the appropriate contact (a relay contact, e.g.).

By activating this input (electric input pin interconnection) you send one SMS to one pre-programmed telephone number.

Caution! Do not use in life-supporting or property-protection applications because of the character of SMS service and EasyGate. The manufacturer shall not be liable for health and property damage incurred as a result of SMS sending failure.

8. COM – Serial Interface

The complete serial interface RS-232C on a 9-pin connector is identical with any external modem.

The transmission rate ranges from 1200 to 115200 bps (EasyGate supports autobauding, i.e. responds to an AT command at a rate identical with the AT command transmission rate, and retains set on this rate). The transmission setup must be 8 bits, no parity and one STOP bit (8N1).

EasyGate's central processor uses the same interface for establishing calls and so it must have the possibility to block an external serial interface-all PC SW must provide transmission hardware flow control (HW handshaking).

COM can be used for:

- Programming and monitoring;
- CSD PC-PC data transmission;
- CSD or high-speed GPRS connection to the Internet;
- SMS sending and receiving.

8.1. Programming, Monitoring

Install the EasyGate PCManager software available on the included CD-ROM into your PC.

The program is designed for EasyGate parameter programming. It can read configuration data from the memory and store them in EasyGate. Moreover, all parameters can be saved in your PC file for backup or saving into another EasyGate system.

The EasyGate PCManager contains an easy monitoring tool too. With this tool you can identify the GSM provider's name, signal strength, GSM module, SIM, and so on during EasyGate operation.

8.2. CSD PC-PC Data Transmission

The CSD mode provides data transmission in the GSM network at the maximum transmission rate of 14400 bps. It works like a classic connection of two modems (AT commands ATD, ATH, ATA, etc.). Connection can be made with another GSM modem or a PSTN modem.

Caution! Data calls and fax calls from the PSTN come as voice calls (the telephone line on EasyGate rings) because an analog network is unable to distinguish a modem/fax call. Therefore, it is necessary to have a special telephone number for incoming data and fax calls on the SIM card different from voice call numbers (Multi-numbering scheme). The GSM network identifies a call incoming to this number as a data/fax call and lets the COM serial interface ring.

8.3. CSD or High-Speed GPRS Data Connection to Internet

To connect to the Internet, install the faxmodem driver from the EasyGate CD-ROM first. Another possibility is to use the GSM provider's installation wizard in case it supports the SIEMENS GSM module installed in EasyGate (SIEMENS MC39i, MC55, MC56 or MC55i). GPRS/faxmodem driver can be found on installation CD. The path to the driver is \\data\EasyGate\Modem driver\. Driver's filename is mdm2n_vx.x.inf where x.x stands for the version of the driver.

The installation wizard usually configures the telephone connection of the network too. If you use manual installation, you have set it properly. Ask you GSM provider for Internet connection instructions because they can be different for each provider (especially the telephone number to be dialed, DNS, etc.). It is necessary, for example, to set the APN in modem extra settings in the GPRS mode:

Example: at+cgdcont=1,"IP","internet.t-mobile.cz"

Caution! GSM providers mostly specify the *99# number to be dialed for GPRS connection in their instructions. SIEMENS GSM modules require the *99***1# format.

8.3.1. CSD or GPRS Data Connection?

The maximum CSD transmission rate is 14400 bps. GSM connection is reserved for the whole time of connection and calls are charged according to the connection time. The CSD mode can provide data connection of two PCs.

EasyGate is equipped with GSM modules providing GPRS class 10 (4+2 timeslots), which means that it is able to transmit data into a PC at the rate of 85600 bps and at half the rate towards the GSM network. The GPRS cannot be used for connection of two PCs. It can only provide connection with an APN – e.g. the Internet. Most GSM providers charge GPRS connections according to the volume of data transmitted or by a lump sum and so the GPRS is suitable for long-time connection with occasional data transmissions.

8.4. SMS Sending and Receiving

It is possible to send and receive SMS units using appropriate AT commands. There are a number of PC programs that are based on this principle. Install SW designed for SIEMENS GSM modules (SIEMENS mobile telephone SW can also be used). You can send and receive SMS even during EasyGate voice calls.

8.5. Combination of COM Traffic with Voice Calls

As already mentioned, SMS transmission can be made even during telephone calls. The SMS program is only blocked temporarily during outgoing call establishing and incoming call ringing.

The same applies to PCManager monitoring. A message announcing that EasyGate is blocked is displayed during voice call establishing.

No voice call can be made during CSD data connection.

Outgoing and incoming calls can be made during GPRS connection. The GPRS connection remains active during the whole call but no data can be transmitted

(EasyGate is a GPRS terminal of class B). Once the call is terminated, data transmission is recovered immediately.

8.6. List of Supported AT Commands

There are original files related to SIEMENS GSM modules in the PDF format on the EasyGate CD-ROM.

Caution! Since the GSM module is primarily used by the EasyGate central processor for voice calls, use AT commands carefully. You might misconfigure the GSM module thus making EasyGate inoperative. To solve most of these problems, switch EasyGate off and on again to make the central processor execute full initialization of the GSM module.

Do not use particularly:

ATQ1	AT+CMUT=	AT^SNFI=
ATS3=	AT+CMUX=	AT^SNFM=
ATS4=	AT+CSCS=	AT^SNFO=
ATS5=	AT^SAIC=	AT^SNFPT=
ATV0	AT^SM20=	AT^SNFS=
AT&C0	AT^SMSO=	AT^SNFV=
AT+IPR=	AT^SNFA=	AT^SNFW=
AT+CFUN=	AT^SNFD=	

9. EasyGate Parameter Programming

All EasyGate parameters have such default values that meet most users' demands and need not be changed. To change EasyGate parameters in spite of that, you can either:

- Use a PC with the PCManager installed. All functions supported by EasyGate can be set using the PC.
- Or use the DTMF programming on a telephone line. Not all functions can be set in this way.





9.1. Telephone Line based Programming

1. Hook off the telephone, you can hear the dial tone or the busy tone, and the Line LED starts flashing.
2. Enter the service password (12345 by default, can be changed) with the DTMF; to cancel a wrong password hang up before sending the character.
3. To confirm password enter a .
4. If you have entered a correct password, you hear the confirmation tone. If not, the dialed number may be sent to the GSM network as a call. To prevent this, hang up when you do not hear the confirmation tone.
5. EasyGate shall remain in the programming mode until hang-up.
6. Enter the number of the parameter to be programmed and press a . If the parameter number is correct, you can hear the confirmation tone, if not, you get the refusal tone and can re-enter the parameter number.
7. When the parameter number is confirmed, enter the allowed parameter value and press a . If the parameter value is in the allowed range, you can hear the saving tone, if not, you get the refusal tone. You can enter another parameter number in either case.

Numeric parameters are programmed using numbers in units included in the parameter description. For YES/NO parameters use for YES and for NO.

To cancel any programming step in the programming mode, press a . Having done so, you can hear the refusal tone and can enter a new parameter number. Parameters are saved when the saving tone is transmitted. Hang up to quit programming.

Example:

<input type="text" value="1"/> <input type="text" value="2"/> <input type="text" value="3"/> <input type="text" value="4"/> <input type="text" value="5"/> <input type="text" value="*"/>		Password entering, OK
<input type="text" value="1"/> <input type="text" value="0"/> <input type="text" value="*"/>		Transmission volume parameter, OK
<input type="text" value="3"/> <input type="text" value="*"/>		Set to medium level, saved
<input type="text" value="5"/> <input type="text" value="5"/> <input type="text" value="*"/>		Non-existent parameter number, refusal

9.2. PC based Programming

For programming, connect EasyGate to a PC with a serial cable and make sure that the EasyGate PCManager is installed. Programming is intuitive and easy. All steps are accompanied with texts hints above all items you point at with the mouse.

EasyGate data uploading and storing, including firmware upgrade, are executed in a special mode, in which EasyGate waits for about 3s after power up (all LEDs are on). If instructed so by the PCManager during this timeout, EasyGate remains in this mode as long as it is necessary. If EasyGate is not reset after the PCManager is terminated, switch the system off and on again.



9.2.1. Basic Programming Instructions

1. Run the PCManager and select the language for displaying texts on the right-hand side.
2. Click on the CD-ROM icon for data handling on the left-hand side.
3. Load data from EasyGate – if EasyGate is not in its special programming mode, you are invited to switch EasyGate off and on again.
4. Click on the programming table icon on the left-hand side.
5. The parameters are arranged according to their functions in the tables. Set all parameters you want to change. If you point at a parameter with the mouse, help is displayed.
6. Click on the CD-ROM icon again for handling data.
7. Save data into EasyGate – if EasyGate is not in its special programming mode, you are invited to switch EasyGate off and on again.

9.2.2. Further Data Handling Options

In addition to the EasyGate memory, settings can be saved in a PC file and reloaded into the PCManager. This is recommended for backing up of current configurations or saving the same configuration in another EasyGate unit.

Caution! The table Security includes the PIN code and service password. These parameters have a special handling. They are not saved in a PC file for security reasons. If you load a PC file into the PCManager and then into EasyGate, the PIN and service password should not change unless you change them manually before saving.

Caution! All tables are filled-in with default values after PCManager start. It is recommended to load data from EasyGate before parameters programming and saving. If you only save data after PCManager start, all parameters except the PIN and service password in the EasyGate memory will have default values.

Caution! The PIN and service password can only be modified either manually or by full initialization.

9.2.3. Upgrade

The manufacturer responds to clients' requirements with periodical firmware updating. The current EasyGate firmware, PCManager and User Manual are available on www.2n.cz. The latest firmware version is always included in every new PCManager installation.

Upgrading procedure:

1. Run the PCManager, select the language for displaying texts on the right-hand side.
2. Click on the CD-ROM icon for data handling on the left-hand side.
3. Click on the upgrade – if EasyGate is not in its special programming mode, you are invited to switch EasyGate off and on again.
4. The upgrade takes place automatically. **Do not switch your PC or EasyGate off during the process of upgrading!**

Caution! The PCManager checks the software version in EasyGate and the upgrade file. If the version in the file is new, everything is all right. An identical or earlier software version is stored in EasyGate too but the PCManager requires confirmation to be on the safe side.

Caution! With regard to potential EasyGate memory data structure change, the PCManager and EasyGate are "matched" according to versions. A PCManager version can be used for EasyGate programming that differs from the EasyGate version by a letter following the version number (e.g.1.00A). The PCManager itself identifies this fact and notifies you.

9.2.4. Monitoring

Monitoring is active when EasyGate is in operation and registered to the GSM network. If EasyGate is not registered to GSM, the COM is locked and no monitoring can be made.

This simple informative function helps you identify:

- The GSM module type and IMEI ID;
- The SIM card IMSI ID and selected SMS service centre necessary for SMS sending;

- The GSM provider's name and signal strength received by EasyGate - this information helps you find the optimum signal location (the information is updated in 10s intervals);
- The EasyGate line status – standby, outgoing call, incoming call including telephone number. The COM is locked during dialing and incoming call ringing, so the PCManager reports COM blocking.



9.2.5. Other control buttons

In the bottom of PC Manager window there can be found buttons for closing the application, minimizing into the tray and showing information about application. You can change the COM port for communication with EasyGate with button Setup. The chosen port must be the same with which is EasyGate connected to PC.

9.3. Parameter Tables

All programmable parameters are listed in this section. Each parameter is accompanied with the unit used, function number (if available) for programming via a telephone line, description of EasyGate's behavior, setting options, setting step and default (initialization) value.

9.3.1. Telephone Line Parameters

9.3.1.1 Dialing parameters

Type of dialing Function No.: -
 Select the dialing type to be received by EasyGate from the PBX or telephone set. EasyGate accepts only the selected type of dialing, ignoring the others.
 Setting options:
 DTMF -EasyGate receives tone dialing only.
 Pulse -EasyGate receives pulse dialing only
 Default setting: DTMF

Time to dial [s] Function No.: -
 Timeout during which EasyGate waits for further digits to be dialed. It starts to establish connection when this timeout passes.
 Setting options: 1-15 s
 Setting step: 1 s
 Default setting: 5 s

Minimal On Hook [ms] Function No.: -
 The minimum line current discontinuation that EasyGate evaluates as hang-up.
 Setting options: 100-1500 ms
 Setting step: 100 ms
 Default setting: 500 ms

Beep after dialing end Function No.: -
 Select a beep to signal the end of dialing (beginning of outgoing call establishing).
 Setting options: YES/NO
 Default setting: YES

9.3.1.2 Signaling

Line reversal indication for call in progress Function No.: -
 Select call in progress signaling by telephone line polarity reversal. There is voltage of reversed polarity on the telephone line during the whole call.
 Setting options: YES/NO
 Default setting: NO

Tariff pulse when call starts/ends Function No.: -
 Signaling of call start or end by tariff pulse.
 Setting options:

- None -EasyGate doesn't send tariff pulse as signaling of call start/end.
- Call end -EasyGate sends tariff pulse when call ends.
- Call start -EasyGate sends tariff pulse when call starts.
- Call start and end -EasyGate sends tariff pulse when call starts and ends too.

Default setting: None

Tariff pulse frequency Function No.: -

Tariff pulse frequency setting.

Setting options:

16 kHz -EasyGate transmits 16 kHz tariff pulses

12 kHz -EasyGate transmits 12 kHz tariff pulses

Default setting: 16 kHz

9.3.1.3 Tone settings

Dial tone – Double frequency tone[Hz] Function No.: -

Set for double frequency tones

Setting options: YES/NO

Default setting: NO

Dial tone – frequency [Hz] Function No.: -

Setting of frequency/frequencies of dial tone.

Setting options: 5-1275 Hz

Setting step: 5 Hz

Default setting: 425 Hz

Dial tone - cadence Function No.: -

This tone is generated after Off-Hook in case EasyGate is ready to accept dialing.

Setting options:

Continuous -EasyGate generate continuous dial tone

Morse A -EasyGate generate dial tone with 320/320/640/640 ms cadence

Default setting: Continuous

Busy tone – Double frequency tone[Hz] Function No.: -

Set for double frequency tones

Setting options: YES/NO

Default setting: NO

Busy tone – frequency [Hz] Function No.: -

Setting of frequency/frequencies of busy tone.

Setting options: 5-1275 Hz

Setting step: 5 Hz

Default setting: 425 Hz

Busy tone - cadence Function No.: -

Busy tone cadence setting.

Setting options:

330/330 ms -cadence 330 ms tone, 330 ms pause

200/200 ms -cadence 200 ms tone, 200 ms pause

250/250 ms -cadence 250 ms tone, 250 ms pause

375/375 ms -cadence 375 ms tone, 375 ms pause

500/500 ms -cadence 500 ms tone, 500 ms pause

Default setting: 330/330 ms

Tone after disconnection Function No.: -

If the remote subscriber hangs up first, the EasyGate subscriber can hear the tone selected here.

Setting options:

Busy -EasyGate transmits the busy tone upon call end.

Permanent -EasyGate transmits the permanent tone upon call end.

Default setting: Busy tone

9.3.1.4 Volumes

Transmission volume Function No.: 10

Volume setting for GSM transmission with a 4 dB step.

Setting options: 1-5

Setting step: 1

Default setting: 3 = medium volume level

Reception volume Function No.: 11

Volume setting for GSM reception with a 4 dB step.

Setting options: 1-5

Setting step: 1

Default setting: 3 = medium volume level

9.3.1.5 Ringing signal settings

Ringing signal – frequency [Hz] Function No.: -

Ringing signal frequency setting.

Setting options:

25 / 50 Hz

Default setting: 50 Hz

Ringing signal - cadence Function No.: -

Ringing signal cadency setting.

Setting options:

1000/4000 ms - 1 s ring, 4 s pause

400/200/400/2000 ms - 400ms ring, 200ms pause, 400ms ring, 2s pause

1500/3500 ms - 1,5 s ring, 3,5 s pause

2000/4000 ms - 2 s ring, 4 s pause

Default setting: 1000/4000 ms

Ringing signal DATA/Fax – cadence

Function No.: -

Ringing signal cadency for Data/Fax setting.

Setting options:

- 1000/4000 ms - 1 s ring, 4 s pause
- 400/200/400/2000 ms - 400ms ring, 200ms pause, 400ms ring, 2s pause
- 1500/3500 ms - 1,5 s ring, 3,5 s pause
- 2000/4000 ms - 2 s ring, 4 s pause

Default setting: 1000/4000 ms

CLI transmitting

Function No.: 19

Set this item to enable/disable identification of a telephone line calling from a GSM network. The function can be enabled if you have a device on your telephone line that is capable of receiving FSK according to ETSI standards.

Setting options:

- Disable - EasyGate does not transmit the CLI.
- FSK during ringing - EasyGate transmits the FSK-based CLI according to the ETSI EN 300 659 standard (transmission during ringing).
- Tbd. - prepared for future use

Default setting: Disable

Replace character + in CLI by

Function No.: -

If this parameter is filled, the + character in the international prefix of CLI is replaced by the defined string. The + character can neither be transmitted by the FSK protocol nor dialed by the DTMF from a terminal.

Setting options: 0-15 characters (0-9,*,#)

Default setting: blank

9.3.1.6 Automatic call

BabyCall number

Function No.: -

A number to be dialed for the automatic call function. If this item is blank, the function is disabled.

Setting options: 0-15 characters (0-9,*,#,+)

Default setting: blank

BabyCall timeout [s]

Function No.: -

Time between line Off-Hook and automatic call beginning (if enabled). During this timeout EasyGate waits for dialing that cancels the automatic call. You can make standard call if the BabyCall function is enabled.

Setting options: 0-15 s

Setting step: 1 s

Default setting: 0 s

9.3.2. FXS Routing Parameters

All parameters related to the number dialed for an outgoing call are arranged in this table. According to the prefix you can:

- Bar the number to be dialed - the calling subscriber hears the busy tone;
- Accelerate connection establishing by knowing the number length for the given prefix;
- Accelerate connection establishing by allowing to terminate dialing with a #;
- Modify the number to be dialed by removing and/or adding digits.
- Set tariff metering for the given prefix.

Every table line includes a prefix (of variable length) plus parameters that define EasyGate's behavior in case the beginning of the dialed number matches this prefix. The table can contain up to 20 different prefixes.

There may be exceptions to the rule - a number may start with the same digits but has to be served in a different way. Any table line that starts with the same prefix followed by one or more digits is considered an exception of the line with shorter prefix.

Remember to complete the "Other numbers" line for a number whose prefix is not included in the table.

An example in the figure below shows how to bar all international calls with the exception of calls to Slovakia including dialing acceleration by selecting the number length parameter and tariff setting (5 impulses after call connect and then one impulse every 10 seconds). All other calls are enabled and their tariff is one impulse every 30 second.

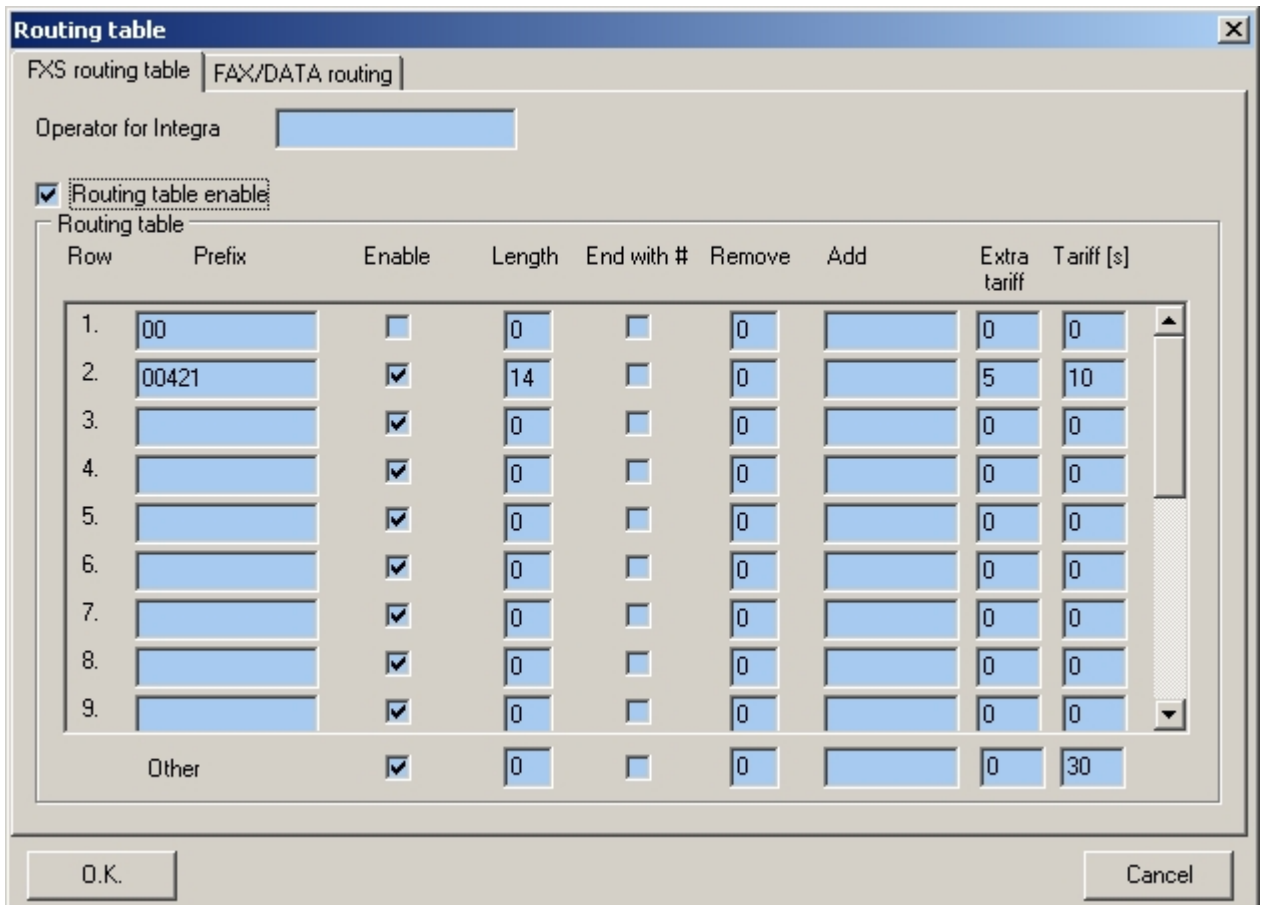

The screenshot shows a dialog box titled "Routing table" with two tabs: "FXS routing table" (selected) and "FAX/DATA routing". Below the tabs is a text field for "Operator for Integra". A checked checkbox labeled "Routing table enable" is present. The main area contains a table with the following columns: Row, Prefix, Enable, Length, End with #, Remove, Add, Extra tariff, and Tariff [s].

Row	Prefix	Enable	Length	End with #	Remove	Add	Extra tariff	Tariff [s]
1.	00	<input type="checkbox"/>	0	<input type="checkbox"/>	0		0	0
2.	00421	<input checked="" type="checkbox"/>	14	<input type="checkbox"/>	0		5	10
3.		<input checked="" type="checkbox"/>	0	<input type="checkbox"/>	0		0	0
4.		<input checked="" type="checkbox"/>	0	<input type="checkbox"/>	0		0	0
5.		<input checked="" type="checkbox"/>	0	<input type="checkbox"/>	0		0	0
6.		<input checked="" type="checkbox"/>	0	<input type="checkbox"/>	0		0	0
7.		<input checked="" type="checkbox"/>	0	<input type="checkbox"/>	0		0	0
8.		<input checked="" type="checkbox"/>	0	<input type="checkbox"/>	0		0	0
9.		<input checked="" type="checkbox"/>	0	<input type="checkbox"/>	0		0	0
	Other	<input checked="" type="checkbox"/>	0	<input type="checkbox"/>	0		0	30

At the bottom of the dialog are "O.K." and "Cancel" buttons.

Operator for Integra

Function No.: -

In some GSM networks you can add to dialed number # character and PBX subscriber number. Subscriber number is displayed on other side together with CLI. This parameter take place when dialed number doesn't contain # character.

Setting options: 0-8 characters (0-9)

Default setting: blank

Routing table enable

Function No.: 20

Enable the use of the routing table with this parameter. Disabling this parameter you put the table out of use.

Setting options: YES/NO

Default setting: NO

Prefix

Function No.: -

A prefix identifying the call type (GSM, trunk call, free call, etc.). "Other numbers" line is used for calls with prefixes that are not included in the table.

Setting options: 0-14 characters (0-9,*,#)

Default setting: blank

Call enable

Function No.: -

This parameter allows/bars calls with prefixes included on the same line.

Setting options: YES/NO

Default setting: YES

Number length

Function No.: -

The parameter defines the expected length of a number with a prefix included on the same line. This enables to start dialing into a GSM network immediately after the last digit is dialed. If the telephone number to be dialed is shorter, a timeout is respected. The "0" setting means that the function is disabled.

Setting options: 0, 3-15

Setting step: 1

Default setting: 0

End with #

Function No.: -

This parameter enables to establish the call when a # is received. The # character is removed from the dialed number. If a # should be part of the dialed number, this function cannot be used for the given prefix.

Setting options: YES/NO

Default setting: NO

Remove

Function No.: -

The Remove parameter is used for automatic call routing. A defined count of digits (prefix) is removed from the number beginning.

Setting options: 0-20

Setting step: 1

Default setting: 0

Add

Function No.: -

The Add parameter is used for automatic call routing. A defined string (prefix) is

added to the beginning of the number to be dialed.

Setting options: 0-8 characters (0-9,*,#,+)

Default setting: blank

Extra tariff

Function No.: -

Pseudo tariff metering setting (tariff is based on call duration). The Extra tariff parameter defines transmitting of fixed quantity of tariff pulses after call start. This parameter sets minimal call cost.

Setting options: 0-255

Setting step: 1

Default setting: 0

Tariff [s]

Function No.: -

Pseudo tariff metering setting (tariff is based on call duration). The Tariff parameter sets the call cost according to call duration. Set how often in seconds do you want to transmit pulses. Smaller number means more expensive call. 0 means not to transmit pulses according to call duration.

Setting options: 0-255 s

Setting step: 1 s

Default setting: 0 s

9.3.3. FAX/DATA routing parametres

Incoming FAX/DATA from GSM network can be routed to telephone line FXS or to COM (PCFax, communication software). Parameter takes place only on models with FAX converter, on other models FAX/DATA calls are routed always to COM.

FAX from GSM network routing

Function No.: -

FAX from GSM network is routed to selected interface

Setting options: FXS line/COM

Default settings: FXS

DATA from GSM network routing

Function No.: -

DATA from GSM network are routed to selected interface

Setting options: FXS line/COM

Default settings: FXS

9.3.4. SMS Sending Input Parameters

Telephone number for SMS

Function No.: -

The telephone number to which an SMS is sent upon SMS input activation. If blank, the function is off.

Setting options: 0-16 characters (0-9,*,#,+)

Default setting: blank

SMS text

Function No.: -

The SMS text to be sent to the preset telephone number. If the SMS text is blank, an empty SMS is sent.

Setting options: 0-40 characters

Default setting: blank

Send if activated longer than [ms]

Function No.: -

Set the SMS activation time necessary for SMS sending. This parameter prevents SMS sending in the event of short-time activation. If a "0" is selected, SMS is sent immediately upon the input activation.

Setting options: 0-25500 ms

Setting step: 100 ms

Default setting: 0 ms

Timeout after sending [s]

Function No.: -

Set the Time of inactivity after SMS sending. During this timeout no SMS is sent even if the SMS input gets activated. This prevents sending multiple SMS units in the case of repeated activation of the input.

Setting options: 0-2550 s

Setting step: 10 s

Default setting: 0 s

9.3.5. GSM & SIM Parameters

GSM operator lock Function No.: -
 Provider blocking is set by manufacturer in EasyGate. If EasyGate is blocked to a GSM provider, no other GSM provider's SIM card can be used. If an unacceptable SIM card is used, the GSM modules does not registered to GSM and the GSM network LED flashes quickly on the EasyGate panel.

CLIR - incognito Function No.: 41
 Sets the calling line identification restriction (CLIR) for outgoing calls from EasyGate. Attention, before enabling it is necessary to activate this feature by GSM operator, otherwise outgoing calls can be rejected by GSM network.
 Setting options:
 -According to provider - depending on how the function is selected in the GSM network
 -Activation - ID is not sent.
 -Suppression - ID is always sent.
 Default setting: According to provider

Roaming enable/disable Function No.: 42
 You can make EasyGate work even if it is registered to a foreign GSM network.
 Setting options:
 -Disable -The GSM module logs out of a foreign network and attempts to register again in within 5 minutes.
 -Enable -EasyGate works in any GSM network.
 Default setting: Disable

Incoming calls enable Function No.: 43
 With this parameter you can reject all incoming calls.
 Setting options:
 Enable - Incoming calls ring on the telephone line.
 Disable - Incoming calls are rejected.
 Default setting: Enable

Call Handover workaround Function No.: -
 This parameter offers a workaround to prevent problems during call handover into the 1900 MHz (or 1800 MHz) band, caused by non-conforming configurations of the 1900 MHz (or 1800 MHz) GSM network.
 Setting options:
 -Disable -Disable workaround.
 -Enable -Enable workaround.
 Select only when handover into a 1800/1900MHz band fails.
 Default setting: Disable

9.3.5.1 Low credit checking in prepaid SIM

Time period for low credit checking [h] Function No.: -
 Set to change time interval between credit checks. If your credit drops under

defined value, EasyGate sends SMS "LOW CREDIT". The "0" setting means that the function is disabled.

Setting options: 0-255 h

Step: 1 h

Default setting: 0

Code for credit checking

Function No.: -

Credit in prepaid SIM cards is checked by network function, which displays text message on mobile phone display. Code of network function must be terminated with "#" symbol.

ATTENTION - find out if you have to pay for this function. Every check can lower your credit.

Setting options: 0-8 characters (0-9,*,#,+)

Default setting: blank

Minimal credit

Function No.: -

Set minimal credit value to send warning SMS "LOW CREDIT". If credit is lower than given value, warning SMS is send after every credit check, until you recharge your SIM card.

Setting options: 0-999

Step: 1

Default setting: 0

Credit value position in received SMS

Function No.: -

If there are more numbers except credit value in text answer (e.g. date, time and so on) EasyGate seeks the number corresponding with credit value from given position in text. The seek algorithm skips every non-number character. If credit value is the first number in text you can leave setting 0. If there are other numbers before credit value, set parameter to text position, from which the algorithm will seek.

Setting options: 0-180

Step: 1

Default setting: 0

Telephone number for service SMS

Function No.: -

Telephone number for service SMS. The number is common for GGMC SMS and "LOW CREDIT" SMS on prepaid SIM cards.

Setting options: 0-16 characters (0-9,*,#,+)

Default setting: blank

9.3.6. Service Parameters

- Hardware version** Function No.: -
 EasyGate hardware version - for information only (cannot be modified). Must be used for communication with the manufacturer.
- Firmware version** Function No.: -
 EasyGate firmware version - EasyGate central processor program version. The manufacturer can issue upgrades to extend functions. To load new firmware into EasyGate use the Upgrade function. Keep communicating with the manufacturer.
- Serial number** Function No.: -
 EasyGate serial number - for information only (cannot be changed). Must be used for communication with the manufacturer.
- GSM operator lock** Function No.: -
 Refer to GSM & SIM Parameters.
- COM enable** Function No.: 50
 With this parameter you can enable/disable the serial interface function. You can disable communication in the operating mode, maintaining the special programming mode after power up.
 Setting options: YES/NO
 Default setting: YES
- Time period for GGMC SMS [h]** Function No.: -
 Time interval for GGMC SMS sending. GGMC = GSM Gateway Monitoring Centre. The "0" setting means that the function is disabled.
 Setting options: 0-255 h
 Step: 1 h
 Default setting: 0
- Telephone number for service SMS** Function No.: -
 Telephone number for service SMS. The number is common for GGMC SMS and "LOW CREDIT" SMS on prepaid SIM cards.
 Setting options: 0-16 characters (0-9,*,#,+)
 Default setting: blank

9.3.7. Initialization

All programmable parameters are arranged in tables according to their functions. You can initialize either all parameters at once or one table of parameters.

For initialization via a telephone line fill in the function number according to the type of initialization and enter the service password as the parameter.

Telephone line initialization	Function No.:	91
Initialization of all parameters necessary for the telephone line function.		
Call table initialization	Function No.:	92
Initialization of all parameters related to dialed telephone number.		
Initialization of GSM & SIM	Function No.:	94
Initialization of all parameters related to the GSM network and SIM card (except for the PIN code).		
SMS input initialization	Function No.:	93
Initialization of all parameters for SMS sending upon SMS input activation.		
Global initialization	Function No.:	99
Initialization of all EasyGate parameters including the PIN and service password.		

9.3.8. Security Parameters

PIN - value

Function No.: 40

Fill in the PIN value for automatic PIN entering upon EasyGate power up. It is applied only if the SIM card is PIN secured. If the given PIN fails to match the SIM, it is deleted automatically. If entered via a telephone line upon EasyGate start, the PIN is stored automatically.

Setting options: 0, 4-8 characters (0-9)

Upon full initialization: blank

Service password

Function No.: 90

Fill the service password for programming via a telephone line. Some parameters can be programmed by DTMF dialing and so the access to programming must be password-protected.

Setting options: 4-8 characters (0-9)

Upon full initialization: 12345

10. Troubleshooting

No LED is on after power up

- Check the power supply.

All LEDs are on. No call is currently in progress.

- EasyGate is in the special PCManager-based programming mode - exit the PCManager to reset EasyGate.
- Try to switch EasyGate off and on, the LEDs should go off in 3s and signal the status of EasyGate.

EasyGate does not register to GSM

- Check the SIM card.
- Check the PIN.
- Check the antenna connection.
- Select a place with a good GSM signal.

No tone can be heard after line off-hook

- Check the telephone line connection.
- EasyGate is not initialized properly upon start (approx. 10s after power up).
- EasyGate is not supplied with power.

EasyGate keeps transmitting a tone during dialing, not receiving the dialing

- Select the correct dialing type (DTMF or pulse).

EasyGate does not communicate with PC

- Check the serial cable connection.
- Check the COM number setting on PC.
- Check the COM parameters (1200-115200 bps, 8N1).
- EasyGate is not registered to GSM network.
- A dialing or outgoing call establishing process takes place on EasyGate.
- An incoming call is ringing on EasyGate.

11. List of Abbreviations

- **APN** - Access Point Name – necessary for the GPRS service
- **CLIP** - Calling Line Identification Presentation
- **CSD** - Circuit Switched Data
- **COM** - PC serial port
- **DTMF** - Dual Tone Multifrequency - tone dialing
- **EG** - EasyGate
- **FSK** - Frequency Shift Keying
- **FXO** - an interface electrically identical with a standard telephone (opposite side = FXS interface)
- **FXS** - a telephone interface allowing standard telephone connection (opposite side = FXO interface)
- **FW** - Firmware - similar to SW, a term for the central microprocessor program
- **GSM** - Group Switched Mobile system - the present standard digital mobile telephone network
- **GPRS** - General Packet Radio Service - high-speed data transmission for GSM networks
- **HW** - Hardware - an electronic device, circuit, board, component, etc. in this context
- **P(A)BX** - Private (Automatic) Branch Exchange
- **PC** - Personal Computer (based on the IBM PC standard)
- **PIN** - Personal Identification Number - a SIM card securing password
- **PUK** - Personal Unblocking Key - a password used to unblock a blocked SIM card after repeated wrong PIN entering
- **RS-232C** - a PC serial port standard
- **SIM** - Subscriber Identity Module - a chip-equipped module to be inserted in a GSM device for identification
- **SMS** - Short Message Service, a term for the system and one unit (message)
- **SW** - Software
- **TTL** - Transistor-Transistor Logic - a standard digital technology defining voltage for levels 0 and 1
- **PSTN** - Public Switched Telephone Network



12. Technical Parameters

GSM:

GSM module, GSM bandwidth	MC39i EGSM 900 / GSM 1800 MC55 EGSM 900 / GSM 1800 / GSM 1900 MC56 EGSM 850 / GSM 1800 / GSM 1900 MC55i EGSM 850/ EGSM 900/ GSM 1800/ GSM 1900
Transmission power	2 W EGSM 850 / 900 MHz, 1W GSM 1800 / 1900 MHz
Receiver sensitivity	-105 dBm
Audio	HR+FR+EFR Half rate+Full rate+Enhanced full rate Echo cancellation, Echo suppression
DATA	GPRS Class 10, 4+2 max. 85.6 kbps downlink CSD max. 14.4 kbps; Coding scheme CS 1, 2, 3, 4
Fax	Fax Group 3 on model with fax converter
Antenna	850/ 900/ 1800/ 1900 MHz 50 Ω SMA antenna connector
SIM card	3V plug-in

Power Supply:

Mains supply	230/12V; 0.5A adapter
DC power supply	10 to 16V DC
12V consumption	Standby 70mA Call/data typ. 200mA max. 300mA
Supply connector	DC Jack 2.1mm

Telephone Interface:

Interface type	2-wire analog, FXS
Telephone connector type	RJ 12, 6/2
Call impedance	600 Ω
Loop voltage	48 V DC
Loop current	max. 40 mA
Loop resistance	max. 800 Ω
Tone frequency	adjustable, default 425 Hz
Dialing type	tone (DTMF) and pulse
Ringing voltage	42 Vrms 50/25 Hz
Calling line identification	CLI during ringing according to ETSI FSK
Tariff pulses	f=16/12 kHz ; Umin=100mVef on 200 Ω
Answer supervision	polarity reversal, 12/16 kHz pulses

SMS Sending Input:

Closed loop resistance	max. 1k Ω
Open loop resistance	min. 25k Ω
Output voltage / current	open loop 3V / short circuit 0,3mA
Input overvoltage protection	max. +/- 12V

Serial Interface:

Interface type	RS-232C
Connector	D-Sub 9 pins
Interface transmission rate	1200 - 115200 bps (autobauding) 8N1

Others:

Dimensions (w/o connectors)	170 x 130 x 45 mm
Operating temperature	0°C to 45°C
Operating status signaling	3 LEDs (on, GSM network, line)

